

Uniden®

Guardian App Cam 25 IP Camera

For more exciting new products please visit our website:
Australia: www.uniden.com.au

OWNER'S MANUAL

IMPORTANT SAFETY INSTRUCTIONS

Damages caused by non-compliance with this Owner's Manual will void the warranty! We will not assume any liability for damages to items or persons caused by improper handling or non-compliance with the safety notices! Any warranty claim will be null and void in such cases.

- Do not drop, puncture or disassemble the camera. DO NOT expose the camera to excessive water or moisture.
- Never tug on the power cords. Use the plug to unplug it from the outlet.
- Do not expose the camera to high temperature or leave it in direct sunlight. Doing so, may damage the camera or cause temporary camera malfunction.
- Use the devices with care. Avoid pressing hard on the camera body.
- For your own safety, avoid using the camera or power off the camera when there is a storm or lightning.
- Disconnect the power adaptor during long periods between usage.
- Use only the accessories and power adaptors supplied by Uniden.

WIRELESS DEVICES OPERATING RANGE

Ensure the signal reception is acceptable between the camera(s) and the WiFi router. If necessary, reduce the distance between them to improve overall system performance. As local internet environments may vary, your device may indicate that the camera is disconnected or may display a black screen. If this occurs, refresh the app.

Item	Requirement/Recommendation
Internet Bandwidth	1 Mbps upload/download speed
Network Requirement	WiFi or 4G (optimize download speed)
Memory Card	microSD, CLASS10, up to 32GB
Device Processor	1.5GHz dual core processor or equivalent

CONTENTS

IMPORTANT SAFETY INSTRUCTIONS	2
CONTENTS	(this page)3
OVERVIEW	4
FEATURES	5
What's in the box?	6
GETTING TO KNOW YOUR CAMERA	7
INSTALLING THE CAMERA	8
NETWORK SETUP	10
Overview	10
Prerequisites	10
Set Up Camera and Smartphone/Tablet	10
Connect Camera and Mobile Device	11
Connect Camera and WiFi Router	11
Set Time Zone	12
Setting up Email Alert.....	13
USING THE APP	15
Accessing your cameras	15
Snapshot Vs Live Video Screen	16
Snapshot Screen Overview	16
Live Video Screen Overview	23
COMMON OPERATIONS	25
MAINTAINING YOUR SYSTEM	26
TROUBLESHOOTING	27
SPECIFICATIONS	30
WARRANTY	32

OVERVIEW

Uniden's Guardian App Cam 25 system works with your smartphone or wireless device to create a powerful home security network. No PC interface is needed to view video on your smartphone or wireless devices. The wireless Guardian App Cam 25 offers superior quality video with true colour. It is suitable for day or night time use.

The Guardian App Cam 25 camera is an indoor/outdoor camera that is splashproof and has an IP66 weather rating. Water can be sprayed on it and it will still work; however, the camera cannot be submerged underwater.

Although this camera can be exposed directly to the rain, it is recommended that, if it is used outdoors, it be mounted under some type of cover like a patio overhang or eave. As rainwater drops start to dry on the camera glass, it can create spots that will reflect the light from the infrared LEDs used for night vision, thus causing lower quality video.

Also, as dust, grime, and cobwebs accumulate on the camera glass, they can reflect light from the infrared LED and might lower video quality. Periodically clean the lens glass with a soft cloth.

FEATURES

System

- No PC required
- Wired connection to router
- WiFi connection to router
- P2P connection
- Records HD 720P up to 20fps
- Manual/Motion recording to microSD (not included)
- Supports up to 32GB microSD (not included)
- High quality H.264 video
- Audio reception

Guardian App Cam 25 Indoor/Outdoor Camera

- IP66 weather-rated
- IR cut filter switch
- Compact design
- Night vision range – up to 12 metres
- Built-in microphone
- microSD card slot (microSD card not included)

Uniden's AppCam App

- Multiple camera viewing and management from single app
- Remote access to recorded video
- Remote snapshot & recording control
- Event notification/Email alert

WHAT'S IN THE BOX?



Guardian App Cam 25
Camera



Camera Stand



Antenna



5V/1.5V Power Adaptor



Quick Start Guide



Screws and Anchors



Micro USB to Ethernet Cable

**Need Help? Get answers at our website:
www.uniden.com.au for Australian model**

***If any item is missing or damaged, contact your place of purchase immediately.
Never use damaged products!***

GETTING TO KNOW YOUR CAMERA

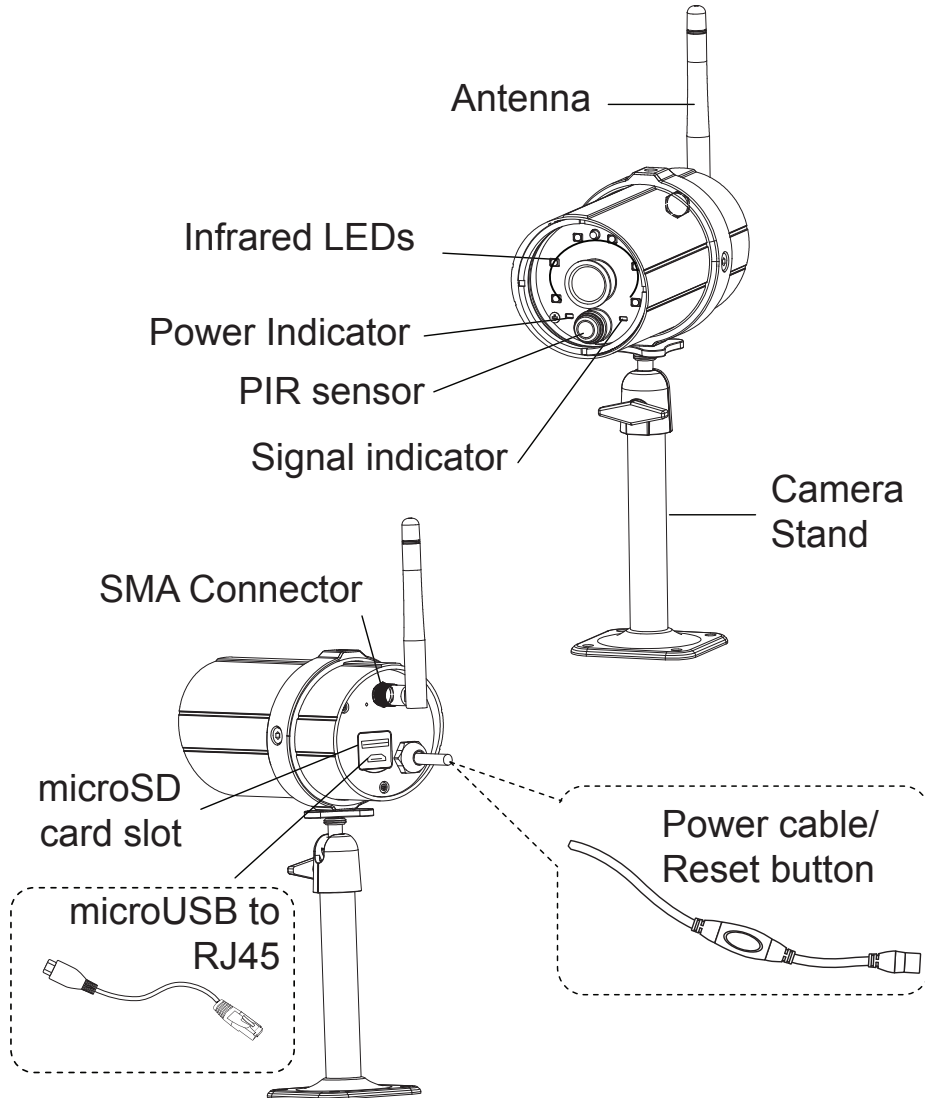

INSTALLING THE CAMERA

Consider the following when installing cameras:

- Clear line of sight video transmission distance is best.
 - Walls, especially brick and concrete, shorten the transmission distance.
 - Placement next to windows allows better transmission.
- Avoid having a direct light source in the view of the camera, including street lights, ceiling or floor lamps, spotlights in the driveway, etc.
- The camera is equipped with built-in infrared LEDs so you can use night vision for 24-hour surveillance. The LEDs will automatically activate at night and the picture viewed will turn to black and white. The night viewing range is up to 12ms. Avoid pointing the camera lens directly at clear glass; the night vision LEDs will cause a blurred image.
- Optimized motion detection range is 1-6ms for the camera. The farther away an object is, the less accurate the motion detection.
- Avoid pointing the camera directly at any bushes, tree branches, or moving objects that might naturally move due to winds. This may cause, the motion detection feature to record unnecessarily.

You can mount the Guardian App Cam 25 with the stand on the bottom (on a flat surface such as a table-top), on the side (on a wall), or on the top (on the ceiling or under an eave or overhang).

1. Use your mobile device to test the places where you are considering mounting the camera. Hold the device in that location; if you still have a WiFi signal on your device, the location should be okay.

Attach the camera stand if you have not already done so.

2. Unplug the camera from the power source and install it.
3. After the camera is installed, reconnect power.

Mount the Guardian App Cam 25 Base

1. Hold the base of the camera stand where you want to mount it and mark the location of the screw holes.
2. Use the included screws and anchors to attach the base to the wall or ceiling. You can also screw the base into a flat surface such as a tabletop if needed.
3. Before attaching the camera, tug gently on the stand to make sure it is securely in place.

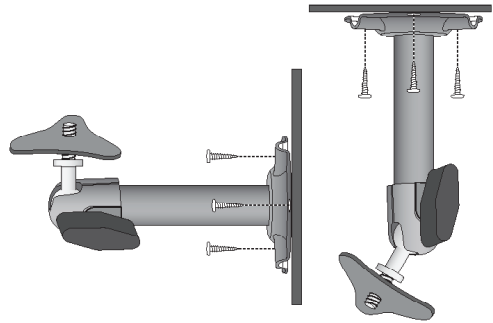

Attach the Guardian App Cam 25 Camera

1. For each Guardian App Cam 25, attach the camera bracket to the mounting screw. You can attach the stand to the top or the bottom of the camera as needed. Tighten it a few turns, then turn the camera to face the direction you want.
2. Tighten the camera brace up against the Guardian App Cam 25 to secure it into place.
3. Unlock the mounting post by turning the wingnut to the left a few turns.
4. Set the mounting post to the correct angle, then tighten the wingnut until the post is locked into place.
5. After the Guardian App Cam 25 camera is installed, reconnect power.

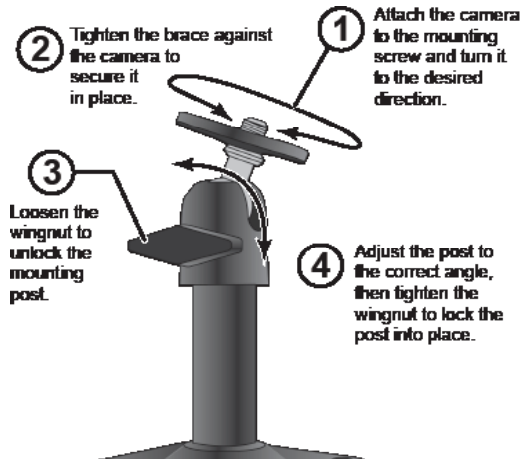

NETWORK SETUP

OVERVIEW

There are two methods of connecting the Guardian App Cam 25 camera to your mobile device. One method is wireless and the other method has the camera connected directly to the router using the provided microUSB to Ethernet cable.

The add camera procedures themselves are identical. In the setup procedures that follow, the wired connection instructions are noted where applicable.

PREREQUISITES

- Your router must support WPA/WPA2 security and it must be turned on.
- You must have an available WiFi-enabled mobile device (Android or iOS smartphone/tablet).
- The Guardian App Cam 25 and your mobile device must connect to the same WiFi router for setup.

SET UP CAMERA AND SMARTPHONE/TABLET



1. Download the Guardian App (search for Uniden® AppCam™ app) from the Apple App Store (iOS) or Play Store (Android) onto your device.
2. Connect the antenna to the camera. You can attach the camera stand to the camera as well but it is not necessary.
3. **Wireless Setup** - Connect the camera to power. After about 45 seconds, the red LED is steady on and the green LED begins to flash (3-flash/pause pattern), indicating that the camera is in Pairing mode.
Wired Setup - Connect the camera to your router using the microUSB to Ethernet cable, provided. Connect to power. Go to **Step 2** in the next section - **Connect Camera and Mobile Device**.

As the Uniden App is constantly under development to enrich user experience, the icons/screens shown in this manual may vary slightly from the actual app. This OM uses icons from the Android device for most of the steps.

CONNECT CAMERA AND MOBILE DEVICE

1. If you are connecting wirelessly, from your device's settings, go to *WiFi*. Select the Guardian App Cam 25 to connect your device to it. The camera listing will be HD-XXXXXX where XXXXXX are the last 6 digits on the camera label. Enter the default password, 12345678. Your mobile device is now connected to the camera.
2. If you are using the wired option, launch the app and tap the *Add New System* icon. 
3. The *System Information* screen displays. Name the camera and tap *Search*.
4. The *Search in LAN* result box displays. The camera's DID should display. Tap the DID number.
5. The *System Information* screen displays again. This time, enter the security code (123456); tap *Save*. Tap *YES*, then *OK* at the next prompts.
6. The *Globe* screen displays. Tap the Globe to access LIVE view.
7. Since this is the first time you connect to LIVE view, you must change the security code. Once you change the security code, you will not be asked again.
8. The app now displays LIVE video.

CONNECT CAMERA AND WIFI ROUTER

1. From the LIVE view, tap Back icon (), the System icon (), and then the System Setting icon (). The *System Information* screen displays.
2. Tap *Advanced*. Enter the Admin password (123456).
3. Scroll to *WiFi* on the Advanced Settings list. Tap *Manage WiFi Network*. Select your router from the drop-down list and enter your router's password. Tap *Connect*.

Your camera will reboot and reconnect to the router. If using the wired set up process, unplug the Ethernet cable from the router and camera during the reboot process. Wait 2 - 3 minutes until the camera's LEDs both return to the steady on state to continue.

4. The camera screen indicates that it is disconnected. Tap the System icon and then the Refresh icon. The camera refreshes and reconnects to the router you chose. The app displays a snapshot of the video image.

At this point, both the red and green LEDs are steady on.



SET TIME ZONE/DAYLIGHT SAVINGS TIME

It is important to set the correct time zone and daylight savings time indication on your camera to ensure correct date/time stamp on the video files.

1. Access the *Advanced Settings* list (see Connect Camera and WiFi Router, described previously).
2. From the *Advanced Settings* list, scroll to *Time Zone*.
3. Select your time zone.
4. Set the Daylight Savings Time indicator.
5. Tap *Back*, and exit the *Advanced Settings* list.

SETTING UP EMAIL ALERT

Set up the email alert so you can be notified when the motion sensor triggers automatic recording.

1. In LIVE view, tap the Back icon (), the System icon (), and then the System Setting icon ().
2. The *System Information* screen displays with the e-mail option as well as the *Advanced* tab.

Android

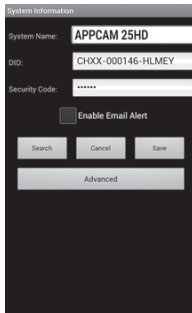

iOS

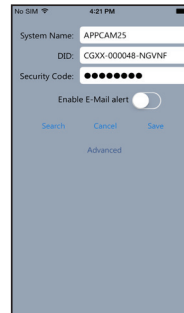

3. Tap the **ENABLE EMAIL ALERT** box (Android) or slide the **ENABLE EMAIL ALERT** button to **ON** (iOS) to turn on email notification when the camera begins recording when it detects movement.
4. Tap *Advanced Settings* and scroll to *E-Mail Setting*. Refer to the table on page 14. Enter your e-mail information in the *Username* and *Receiver* field. You can use the same email address in both the fields.

Android

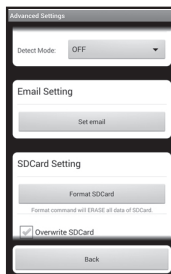

iOS

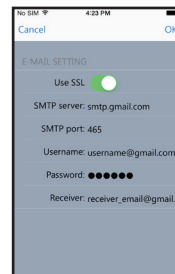

5. Tap **OK** to save your modification.

Setting up a gmail account is recommended. Check SSL and use the data in the following table:

For Gmail		
SMTP Server	smtp.gmail.com	Enter this.
SMTP Port	465	Enter this.
User Name	XXXX@gmail.com	Enter your gmail address in full, including '@gmail.com'.
Password	XXXXXXXXXXXX	Enter the password for this gmail account.
Receiver	XXXX@gmail.com	Enter the email address where you want the alerts sent.

USING THE APP

After you've set up your system, use the Uniden AppCam app to manage your Guardian App Cam 25 operations and to take snapshots and remotely view LIVE or recorded video on your smart phone or tablet device. You can view up to 12 independent Guardian App Cam 25 cameras on the Uniden AppCam app.

As the Uniden App is constantly under development to enrich your user experience, the icons/screens shown in this OM may vary slightly from the actual app.

ACCESSING YOUR CAMERAS

1. Run the Uniden AppCam app.
2. The *Globe* screen displays for each camera set up on the app. Review the names for each camera and tap the globe for the camera you want to view.
3. The *Snapshot* screen displays for that camera. See page 17 for actions available from the *Snapshot* screen. Tap the screen image.
4. LIVE video displays. See page 23 for actions available from the *LIVE Video* screen. Tap  to return to the *Snapshot* screen.

If only one camera is set up on your system, the app displays the Globe screen momentarily and then displays the Snapshot screen for your camera.

SNAPSHOT VS LIVE VIDEO SCREEN

The *Snapshot* and *LIVE Video* screens control operations. The *Snapshot* screen lets you add more cameras, configure advanced settings, access and manage recorded files, update the camera connection status, and check app version.

The *LIVE Video* screen lets you take snapshots and record live video. You can also control the sound.

Android



Snapshot



Live

iOS

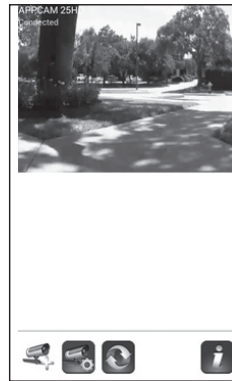

Snapshot



Live



SNAPSHOT SCREEN OVERVIEW

The *Snapshot* screen displays a snapshot image from the camera and four function icons.

Add Another Camera

The  icon allows you to add another camera to your network. Follow the same procedures beginning with Step 2 on page 11.

System Settings

The  icon allows you to configure the advanced settings, remove the camera connection, and play back the recorded video clips. Tap  and the following three icons display in the center of the snapshot image:



Android



iOS



Accesses *System Information - Advanced Screen*. This screen lets you configure the camera and set notification alerts. See page 19 for details.



Deletes the camera from the app.



Event List lets you check and play back recorded events and files. (See page 21 for details.)

Update

Tap  to update the camera's connection status.

Information

Tap  to set up and enable PIN lock or to check the app information.



Android

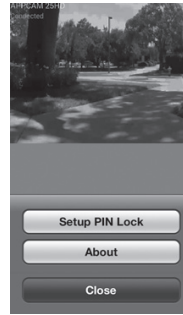

iOS

- The PIN lock is a unique security code you must enter when you start the app.
- APP information displayed includes APP and API version information.
- Android systems can also enable event notification through this button.

iOS systems enable event notification through the iPhone settings (Settings/Notification/UnidenAppCam/Notification Center).

System Information - Advanced Screen Details

Tap  to display the *System Information* screen again with a tab for Advanced settings. From this screen (see page 13 for an image of this screen), you can set email alerts and event notifications as well as configure specific camera settings.

Enable Email Alert

Email alerts notify you when something triggers the motion sensors on your cameras. Tap the box (Android) or move the slider (iOS) to turn this feature on.

Enable Event notify

The system generates event notifications when something triggers the motion sensors on your cameras. Tap the box to turn this feature on.

Advanced

Tap the *Advanced* tab to configure various settings in your device, such as the time zone, device password, and video setting. These settings are displayed in a list of fields, each field contained in its own block. Scroll down to find the field you want to set. You can also format the microSD card or check the device information here.

The Advanced field blocks are:

- *Admin Password*: The security code for your advanced settings. The default Admin Password is 123456. Change the default password to one you set yourself.
- *Time Zone*: Turns daylight savings time on and off and sets up the time zone for your system.
- *Device security code*: Change the default password (123456) to a security code of your choosing for your camera.
- *Video Setting*:
 - Video Quality

Record FPS			
	Better Streaming (VGA)	Better Image (VGA)	HD Better
Live View (Video Quality)	VGA 25fps 256kbps	VGA 20fps 768kbps	HD 10fps 1Mbps
Record (SD Card)	HD 20fps 1.5Mbps	HD 20fps 1.5Mbps	HD 10fps 1Mbps

- Screen Orientation

The options available are Normal, Flip, Mirror and Filp and Mirror.

Normal: The image on the device appears as seen by the naked eye.

Flip: Use this option to flip the images (i.e., if you want to view the images turned upside down).

Mirror: Use this option to view the images as it would appear if seen in a mirror (reversed side).

Flip and Mirror: Use this option to view flipped and mirrored images.

- Environment Mode

This mode enables you to select the power line frequency used at the location of the App Cam 25. The frequency depends on the geographic location. The images may not be very clear if the frequency selected is not correct. Suggested frequency in Australia is 50Hz.

- Low Light Enhancement

This mode improves the night view video image - Level 5 (highest).

- *WiFi Setting*: Set up your WiFi connection.
 - *Sensitivity Setting*: Turn on or off the motion detection sensitivity setting.
 - *Email Setting*: Allows you to configure the email environment, email account, and password. You can also set up encryption for data transmission.
 - *SDCard Setting*: Lets you reformat the SD card and enable/disable the ability to overwrite the microSD card as space is needed.
 - *Profile Setting*: Allows you to save the profile of one camera to apply it to future cameras. You can then customize additional camera using this profile as a base.
 - *Device Information*: Check the model, camera's firmware version, and storage status.
- Unless stated otherwise, the screen returns to the main list of Advanced setting fields after you enter the requested information in a specific field.***

Delete Camera Connection

Tap the Delete icon () to remove a camera from your system. Tap **NO** to keep the camera connection or **YES** to delete it. A confirmation screen displays.

Event List Details

Android

1. Tap the Event List icon () to select a date range of recorded files to display. View a list of recorded video files.
2. Tap the start date and end dates to set the date range. A list of files displays.

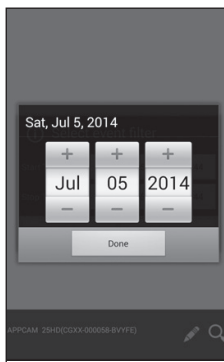
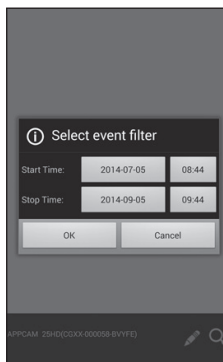

When you set a filter, be sure the Time Zone feature is set accurately in the Advanced fields to reflect the current time zone for the camera, not the time zone where you are. See page 12 for details.

3. Tap the file you want to view and it begins to play.
- Tap the pencil icon to select recorded files to delete. Tap the box on the right side of the entry to select it for deletion.
 - Tap on **SEARCH** (magnifying glass icon) to set up a date range filter. You can use this to change date ranges.

iOS

1. Tap the Event List icon (📅) and then tap the Search icon to set a date range of recorded files to display.
2. Tap the start date and end dates to set the date range. A list of files displays.

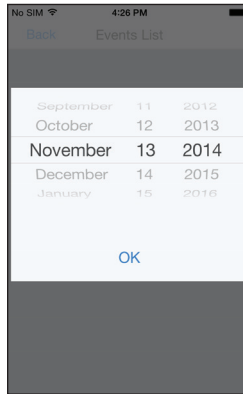
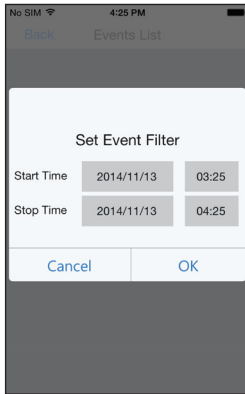

A screenshot of an iPhone app showing the 'Events List' screen. The screen has a 'Back' button at the top left. Below the title 'Events List' is a list of recorded files. Each row contains a date and time.

Date	Time
2014/11/13	16:02:10
2014/11/13	15:12:18
2014/11/13	09:12:34
2014/11/13	09:09:24
2014/11/13	09:02:57
2014/11/13	08:02:52
2014/11/13	08:01:05
2014/11/13	07:59:52
2014/11/13	07:58:13
2014/11/13	07:56:08
2014/11/13	07:53:25

3. Tap the file you want to view and it begins to play.
 - Tap **DELETE ALL** to delete all of the recorded files
 - Tap **DELETE ONE** to delete a single file.

When you set a filter, be sure the Time Zone feature is set accurately in the Advanced fields to reflect the current time zone for the camera, not the time zone where you are. See page 12 for details.

LIVE VIDEO SCREEN OVERVIEW





The *Live Video* screen lets you take snapshots, record video, and turn the sound from the live video on and off.



Android



iOS







	<p>Tap this icon to take a snapshot of the current image. Snapshots are saved in your mobile device.</p>
	<p>Turn the audio on and off when you're viewing live video.</p>
	<p>Tap this icon to begin recording live video.</p> <p><i>Once recording begins, the app continues recording for 1 minute. You cannot stop recording during this period.</i></p> <p>When the system starts recording, the video clips will be saved into your camera's memory card. Please make sure the microSD card has been correctly inserted.</p>
	<p>Return to the <i>Snapshot</i> screen.</p>

TURN OFF THE APP

1. Tap your device's **MENU** button. The **EXIT** button displays.
2. Tap **EXIT**. The app closes and returns to the device's main screen.

For the iPhone, press the HOME button.

COMMON OPERATIONS

To Do This ...	Do This:
Start Recording	From the <i>Live Video</i> screen, tap  . The camera will record for 1 minute .
View Live Video	Tap the image on the <i>Snapshot</i> screen.
View Recorded Files	<ol style="list-style-type: none"> 1. From the <i>Snapshot</i> screen, tap . 2. Tap  from the three icons displayed on the snapshot image. 3. Select a time range of videos to view. 4. Tap your selection from the list of recorded files that now displays. The recorded video begins playing.
Delete Recorded Files	<ol style="list-style-type: none"> 1. From the <i>Snapshot</i> screen, tap . 2. Tap  from the three icons displayed on the snapshot image. A list of recorded videos displays. 3. Android - Tap the pencil icon at the bottom of your list of recorded files. You can now tap the X to select a file to delete. iOS - Tap DELETE ALL or DELETE ONE from the icons along the bottom of the event list.
Take a Snapshot	<ol style="list-style-type: none"> 1. From the <i>Live Video</i> screen, tap . 2. The snapshot is saved on your mobile device.
View Snapshots	Your snapshots are named with a time stamp and saved into the Photo gallery/Snapshot folder on your mobile device.

MAINTAINING YOUR SYSTEM

TAKING CARE OF YOUR CAMERA

When dust and grime builds up on the camera lens and glass, it affects night vision capability. The infrared light reflects off of the dust and grime, limiting the camera's "vision." Use a microfiber cloth to regularly clean the cameras or when night vision video is cloudy or unclear.

MANAGING RECORDED FILES

Over time, your microSD card will fill up with recorded files. If there are files you need to keep, transfer them to your computer for storage and remote viewing. Otherwise, reformat your microSD card every 4 to 6 weeks (see page 25).

Copying Files from the microSD Card to Your Computer

1. Remove the microSD card from the camera.
2. Insert it into your computer's SD card slot. Use an adapter if necessary.
3. Navigate to the microSD card and locate your files.
4. Copy them to the computer. These files can now be deleted from the microSD card or the microSD card can be formatted (see page 25).

TROUBLESHOOTING

HOW TO IMPROVE THE WIRELESS SIGNAL QUALITY

If possible, remove obstacles in between camera and receiver that might reflect the signal. These could include furniture, cabinets, and walls. If the wireless signal is not improved, relocate the camera closer to the receiver.

TROUBLESHOOTING

If...	Try this...
The app cannot find the camera	<ul style="list-style-type: none">• Make sure your network supports DHCP protocol.• Make sure that the DHCP option is turned on.• Make sure the camera and your mobile device connect to the same WiFi router.• Make sure the WiFi router is activated.• Make sure the camera is properly powered on.• Use the “ADD CAMERA” function to manually add the camera.
The camera does not find the router to connect to	<ul style="list-style-type: none">• Make sure you selected the correct router in the <i>Manage WiFi Network</i> box.• Make sure you entered the correct password for the router you selected in the <i>Manage WiFi Network</i> box.
My smartphone or wireless device cannot find the camera during setup.	<ul style="list-style-type: none">• Make sure the router is turned on.• Refresh the connection.• Make sure your smartphone is connected to the same network as the camera.• Make sure the camera’s green LED is blinking in a 3-flash/pause pattern. If it isn’t, reset the camera by pressing and holding the Reset button on the cord until the LEDs begin to flash.

If...	Try this...
No image appears	<ul style="list-style-type: none"> • Make sure the power adaptor is not damaged or defective and is plugged into an electrical outlet with power. • Relocate the camera to obtain the best reception of wireless signals. • Make sure the camera is properly configured in the app.
Poor image quality	Clean the camera lens using a lens cleaning cloth. Spots or dust on the lens can also cause image quality problems.
Motion detection is not working	<ul style="list-style-type: none"> • Make sure the sensitivity setting is not turned OFF. (Set sensitivity through the Advanced tab.) • Adjust the sensitivity of the motion sensor. (Set sensitivity through the Advanced tab.) • In motion detection mode, a moving object within the camera viewing angle is necessary to trigger the motion sensor for recording. • Make sure the system date and time have been correctly set.
Bright white spots appear at nighttime	<p>The camera's infrared LEDs produce invisible light that reflects off surfaces such as glass. Install the camera on the other side of windows or place the lens flush against the surface to improve the night vision.</p> <p style="text-align: center;"><i>Please check the environment rating (Ingress) of the camera(s) before installing outdoors.</i></p>

If...	Try this...
Memory card error	<p>Make sure the memory card is correctly inserted and formatted.</p> <p><i>Please backup the data before formatting. This Format function will erase all data on the memory card.</i></p>
Wrong date and time are shown	<ul style="list-style-type: none"> • Make sure you've selected the correct time zone. Unexpected date and time can result in an incorrect recording schedule. (See page 21) • Confirm the system date/time of the mobile device to ensure correct operation.
Router signal strength is weak	<ul style="list-style-type: none"> • Change router/camera relative position. • Use the Ethernet cable to physically connect the AppCam 25HD camera to your router. • Use a Wi-Fi repeater/extender to maximize the service range of your Wi-Fi router. • Switch your router to 11b/11g mode in order to improve router service range.
Limited internet bandwidth	<ul style="list-style-type: none"> • Avoid more than two users accessing Guardian App Cam 25 at a time.

SPECIFICATIONS

General	
Power	100~240V switching power supply DC 5V/1.5A
Power Consumption	750mA max
Camera Body Dimension	96mm x 48mm diam.
Weight (Main Body)	7.3 oz (210g)
Operating Temperature	14° ~ 122°F (-10° ~ 50°C)
Network	
Wireless Technology	IEEE 802.11 b/g/n
Network Connection	Ethernet (10/100 Base-T/Base -TX); WiFi
Network Protocols	TCP/IP, UDP, SMTP, NTP, DHCP, ARP
Simultaneous Views	3 Concurrent sessions
Security	WPA /WPA2/WPA2-PSK (TKIP, 128 bit AES)
Cameras	
Image Sensor	Mega pixel CMOS
Antenna	3dBi Dipole
Housing	Weather resistant metal
Environmental Rating (Ingress)	IP66
Camera Environment	Indoor (50Hz), Indoor (60Hz), Outdoor
Local Storage	microSD card (not included)
Viewing Angle	H: 50°+/-3 V: 30°+/-3
Min. Illumination	1~8 lux
Low-light resolution	6 IR LEDs with IR switcher
Low-light visibility	up to 12 metres
Min. Upload Bandwidth Requirements	768 kbps per VGA resolution (per camera)

Audio/Video	
Image Compression	H.264
Image Resolution	HD 1280x720
Recording Frame Rate	720P@20FPS
Supported Mobile Internet Device	
Android Requirement	Android 4.1x or above
iOS Requirement	iPhone 4s, iPad Mini, iPad 2with iOS 7.0 or above
Hardware Requirement	<ul style="list-style-type: none"> • 1.5GHz dual core or above • 1GB or above internal memory

WARRANTY

Guardian App Cam 25

Important:

Satisfactory evidence of the original purchase is required for warranty service. Please refer to our Uniden website for any details or warranty durations offered in addition to those contained below.

Warrantor:

The warrantor is Uniden Australia Pty Limited ABN 58 001 865 498 (“Uniden Aust”).

Terms of Warranty: Uniden Aust warrants to the original retail purchaser only that the Guardian App Cam 25 (“the Product”), will be free from defects in materials and craftsmanship for the duration of the warranty period, subject to the limitations and exclusions set out below.

Warranty Period: This warranty to the original retail purchaser is only valid in the original country of purchase for a Product first purchased either in Australia or New Zealand and will expire one (1) year from the date of the original retail sale. If a warranty claim is made, this warranty will not apply if the Product is found by Uniden to be:

- A. Damaged or not maintained in a reasonable manner or as recommended in the relevant Uniden Owner’s Manual;
- B. Modified, altered or used as part of any conversion kits, subassemblies or any configurations not sold by Uniden Aust;
- C. Improperly installed contrary to instructions contained in the relevant Owner’s Manual
- D. Repaired by someone other than an authorized Uniden Repair Agent in relation to a defect or malfunction covered by this warranty; or
- E. Used in conjunction with any equipment, parts or a system not manufactured by Uniden.

Parts Covered: This warranty covers the Product and included accessories.

User-generated Data: This warranty does not cover any claimed loss of or damage to user-generated data (including but without limitation phone numbers, addresses and images) that may be stored on your Product.

Statement of Remedy: If the Product is found not to conform to this warranty as stated above, the Warrantor, at its discretion, will either repair the defect or replace the Product without any charge for parts or service. This warranty does not include any reimbursement or payment of any consequential damages claimed to arise from a Product's failure to comply with the warranty. Our goods come with guarantees that cannot be excluded under the Australian Consumer Law. You are entitled to a replacement or refund for a major failure and for compensation for any other reasonably foreseeable loss or damage. You are also entitled to have the goods repaired or replaced if the goods fail to be of acceptable quality and the failure does not amount to a major failure. This warranty is in addition to and sits alongside your rights under either the COMPETITION AND CONSUMER ACT 2010 (Australia) or the CONSUMER GUARANTEES ACT (New Zealand) as the case may be, none of which can be excluded.

Procedure for Obtaining Warranty Service: Depending on the country in which the Product was first purchased, if you believe that your Product does not conform with this warranty, you should deliver the Product, together with satisfactory evidence of your original purchase (such as a legible copy of the sales docket) to Uniden at the address shown below. You should contact Uniden regarding any compensation that may be payable for your expenses incurred in making a warranty claim. Prior to delivery, we recommend that you make a backup copy of any phone numbers, images or other data stored on your Product, in case it is lost or damaged during warranty service.

UNIDEN AUSTRALIA PTY LTD

Service Division

345 Princes Highway,

Rockdale, NSW 2216

Phone number: 1300 366 895

Email: custservice@uniden.com.au

Uniden®

© 2014 Uniden Australia Pty Limited.