



Uniden[®]

XTRAK **80 Series**

**REMOTE SPEAKER MIC
UHF CB TRANSCEIVER**

For more exciting new products please visit our website:
Australia: uniden.com.au

OWNER'S MANUAL

Contents

Included with your XTRAK	4
Optional Accessories	4
Introduction	5
Features	5
Controls & Connectors	6
Indicators	8
Slide Mount Bracket	9
Connecting the Microphone	10
Mounting the MIC Hanger	11
Operation	12
MENU Order List	12
Turning on the Power	12
Setting the Auto Squelch Level	13
Monitor Mode	13
Selecting a Channel	14
Transmitting & Receiving UHF CB	14
Using UHF CB Repeater Channels	15
Enable / Disable Duplex Mode	15
SMART Key Function	16
Instant Channel	17
Setting the Instant Priority Channel (CH1 or CH2)	17
Recalling the Instant Channel	17
Triple Watch (and Dual Watch)	18
EQL (Equaliser - Voice Enhance Setting)	18
Call Tone (Wake-up-tones)	19
CTCSS (Continuous Tone Coded Squelch System)	20
DCS (Digital Coded Squelch)	20
Scanning	21
Open Scan (OS) Mode	21
Group Scan (GS) Mode	22
Priority Watch for Group Scan	23
Add/Remove Channels from SCAN Memory	23
Master Scan (Uninterrupted Transmit & Receive)	24
Setting up Master Scan Mode	25
Using Master Scan	25
Busy Channel Lockout	26
Roger Beep	26
Key Beep On/Off	27
Alpha Tag	27
Speaker Select	28
Key Backlight / Display Dimmer	28
Voice Scramble	29
Microphone Gain	29

Contents

Operation - Special Features	30
Instant Replay / Receiver Record	30
Turning Instant Replay On/Off	30
100 User Programmable RX Channels	31
Programming a RX Only Channel	31
Selective Calling (SELCALL)	33
Programming the Selcall ID for your Radio	33
Storing Selcall IDs of Other Users to the ID Memory	34
Making a Selcall Call (Tone Calling)	35
TSQ (Tone Squelch) Receiver Quiet Mode	35
Activate/Deactivate TSQ on a Channel	36
Scanning Tone Squelched Channels	36
Receiving a Selcall	37
Group Calling	38
Selcall ID Format	38
SELCALL Settings Menu	39
Tone Period	39
Lead-in Delay	40
Lead-in Delay Programming	40
Lead-in Tone	40
Alarm Mode	41
Call Alarm Auto Mode	41
Call Alarm Continue Mode	41
Group Call Mode	41
Bluetooth App (XTRAK 80 PRO Only)	42
Bluetooth Audio (XTRAK 80 PRO Only)	43
SELCALL Tone Frequency List	44
CTCSS Codes Table	44
DCS Codes Table	45
UHF CB Channel Guidelines	47
UHF CB Channels & Frequencies	48
Warranty	50

Included with your XTRAK



Remote OLED Speaker
Microphone (RM-X80)

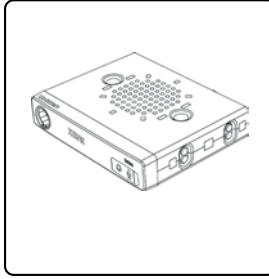

Radio Base Unit

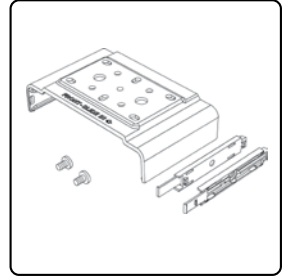

Quick Release Bracket,
Guide Rails, Screws

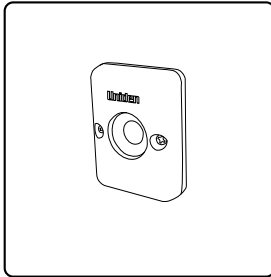

Magnetic Microphone
Hanger

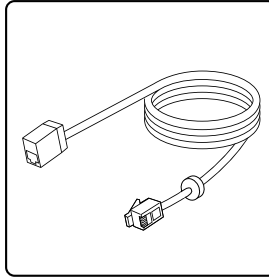

2m Extension Cable
(Cable & adaptor)

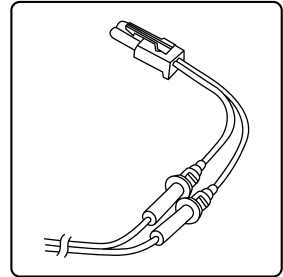

DC Power Cord
with fuse

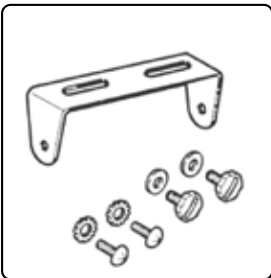

Gimbal Mount Bracket,
Washer, Screws

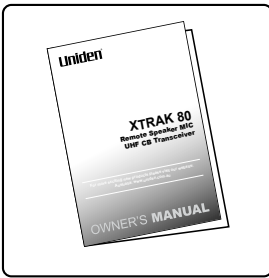

Owner's Manual

- Guide rails for the Quick Release Bracket may be pre-fitted to the base

Optional Accessories

- UHF Antenna
- External Speaker
- Pass through sockets (for MIC cable)

Visit the XTRAK page on the website for more information on the availability of optional accessories: www.uniden.com.au for Australia

Introduction

The Uniden XTRAK is designed to provide you with years of trouble free service. Its rugged components and materials are capable of withstanding harsh environments. Please read this Operating Manual carefully to ensure you gain the optimum performance of the unit.



The citizen band radio service is licenced in Australia by ACMA Radio-communications (Citizen Band Radio Stations) Class Licence and in New Zealand by MBIE General User Licence for Citizen Band Radio and operation is subject to conditions contained in those licenses.

Features

- UHF-CB 80 Channel Narrow Band Transceiver Radio¹
- 5W Transmission Power
- 2W Microphone Speaker
- Duplex Capability¹
- Built-in Selective Calling (SelCall) Feature with Alpha Tag
- Roger Beep Function On/Off
- 10 Different Call Tones

Special Features

- Instant Replay of Recent Received Signals
- 100 Extra User Programmable Receive Only Channels with Alpha Tag²
- 3 One-Touch Smart Keys
- Voice Enhancer (EQL)
- 2 Voice Scramble Settings

Control Features

- Remote OLED Speaker Microphone with 2m Extension Cable
- OLED Display
- Brightness/Dimmer control
- Quick Release Mounting Bracket
- +12V to +24V DC Power Input
- Under and over voltage alert function
- Signal Strength/ Power Meter
- Volume Control
- Base & Remote Mic Speakers

- External Speaker Jack
 - Power On/Off Push Switch
 - Front MIC Jack
 - 10 Level Preset Squelch
-
- Bluetooth® App³ for Location Sharing, Settings Control & Software Upgrades
 - Bluetooth® Audio³ to connect with compatible devices

Channel Features

- Channel Select
- Instant Channel Programming
- One touch Instant Channel recalling
- Triple/Dual Watch with Instant Channel
- Group Scan with Priority Channel Watch
- Open Scan
- Master Scan
- Scan Channel Memory for Open Scan and Group Scan/Master Scan
- Busy Channel Lock-out Function
- 50 Built-in Continuous Tone Coded Squelch System (CTCSS) codes
- 104 additional Digital Coded Squelch (DCS) codes that are user selectable

¹ Refer to p.47 - p.49 for channel information

² Available frequencies & channels are within 400-520MHz Band only in 12.5kHz steps.

³ XTRAK 80 PRO only.

Note: Features and specifications are subject to continual improvement & change.

Controls & Connectors

Base (Front & Rear)

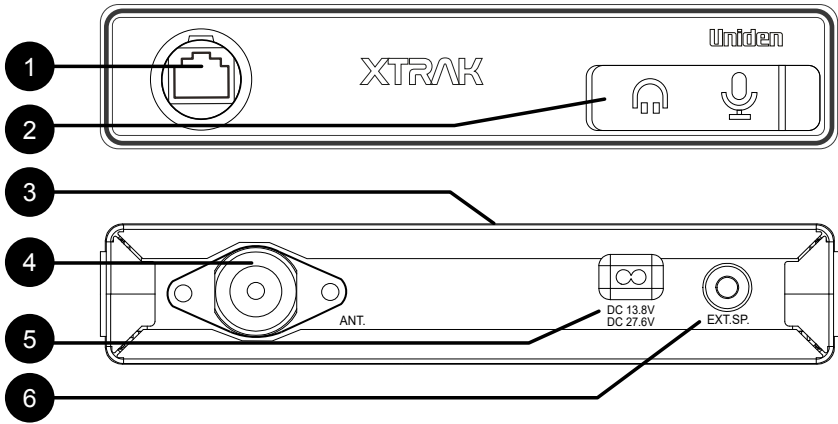

Remote OLED Speaker MIC

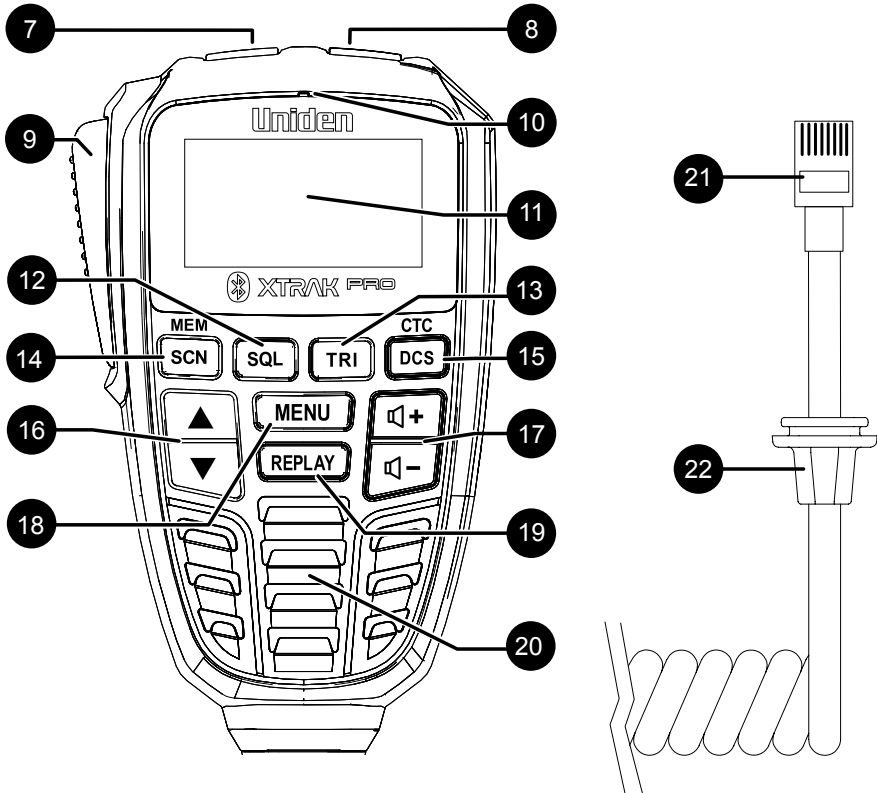

Controls & Connectors

Base (Front & Rear)

- 1 MIC Jack
- 2 Base Update Port (no user function)
- 3 Base Speaker
- 4 UHF Antenna Connection
- 5 Power Input Connection (13.8VDC or 27.6VDC)
- 6 **EXT SP** - External Speaker Jack

Remote OLED Speaker MIC

- 7 **POWER**
 - Power ON/OFF Button (press & hold)
- 8 **[INST /S]***
 - Programmable SMART Key
 - Default: Instant Channel

INST > CALL > EQL > MON > PAI
- 9 **[PTT]** - Push To Talk Button
- 10 **MICROPHONE**
- 11 **OLED** Display
- 12 **[SQL]***
 - Programmable SMART Key
 - Default: Squelch Increment

SQL > CALL > EQL > MON > SELC
- 13 **[TRI]***
 - Programmable SMART Key
 - Default: Triple Watch

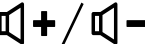
TRI > CALL > EQL > MON > T.SQ
- 14 **[SCAN]** - Scan Button (press)
[MEM] - Memory Button (press & hold)
- 15 **[CTC/DCS]**
 - Open/ Exit Sub-code select
- 16 
[UP / DOWN]
 - Channel, Select Up / Down
- 17 
Volume Up **[VOL +]**
/ Volume Down **[VOL -]**
- 18 **[MENU]**
 - Open/ Select MENU (press)
 - Save & Exit MENU (press & hold)
- 19 **[REPLAY]**
 - Go to/Exit from Replay
- 20 **SPEAKER**
- 21 MIC plug (RJ45 type)
- 22 Front MIC Jack Cover

*See page 16 for how to re-programme a SMART key.

Indicators

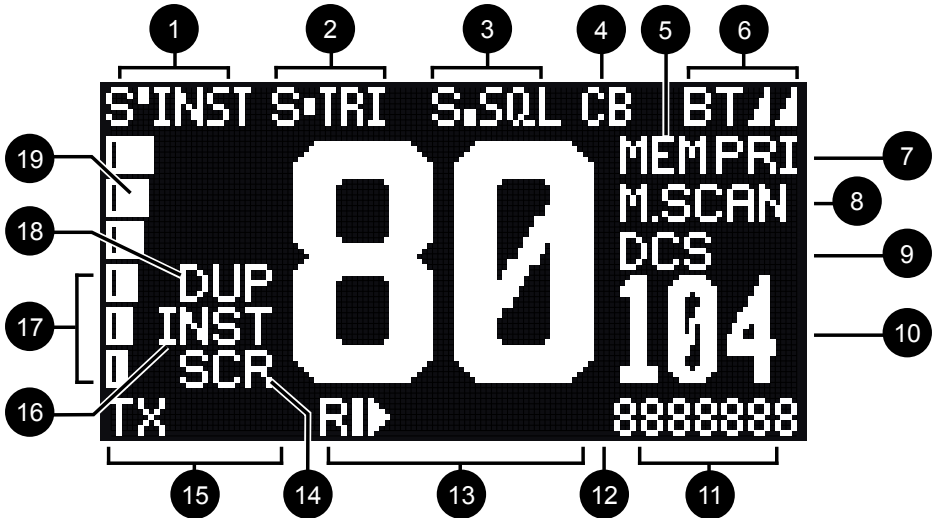

1 **[INST/S]** SMART Key status
INST > CAL > EQL > MON > PAI*

2 **[TRI]** SMART Key status
TRI > CAL > EQL > MON > T.SQ

3 **[SQL]** SMART Key status
SQL > CAL > EQL > MON > SELC

4 **CB** - UHF CB
CB E - Extra RX Only CH Bank*

5 **MEM** - CH is in Scan Memory

6 **BT** - Bluetooth App ON*/Audio ON*

7 Watch mode is ON
PRI / TRI (Priority /Triple-Dual)

8 Scan mode
O.S / G.S - Open / Group
M.S - Master Scan
SCAN - Flashes during scan

9 Sub Code Type
DCS / CTCSS / T.SQ

10 Sub Code No.
 Extra RX Channel No.

11 Alpha Tag or Frequency
EQL# - EQL level

12 UHF CB Channel

13 Replay status
RI - Replay Rec. is ON
RX - Replay Rec. is OFF
 MIC GAIN level (during PTT only)

14 **SCR** - Voice Scramble is ON

15 Transceiver status
TX- Transmitting
CALL - Sending Call Tone
RX- Receiving a Signal
MON - Monitor mode

16 **INST** - CH is an Instant CH

17 Squelch level indication

18 **DUP** - CH is in Duplex
 (Repeater) mode

19 Signal strength meter

*This feature applies to XTRAK 80 PRO only

Slide Mount Bracket

How to attach Slide Mount Bracket?

When you unpack the box, ensure that you have the slide mount bracket, guide rails and the screws. The guide rails may already be pre-fitted to the base unit.

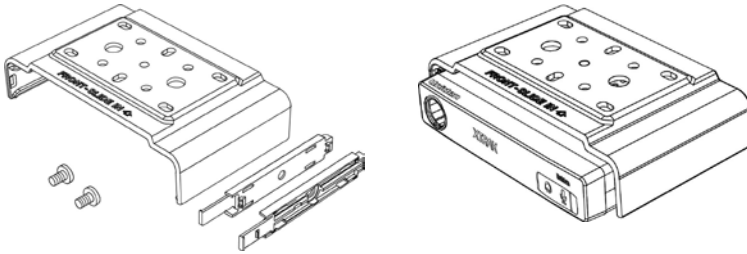

Align the guide rails along the side of the base and insert them into the slots provided. Then use the screws to lock them securely in position.

Slide the bracket along the guide rails to attach the bracket to the unit.

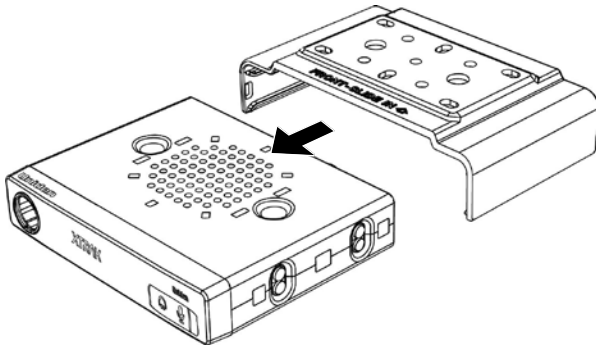

Over the BASE unit

Under the BASE unit

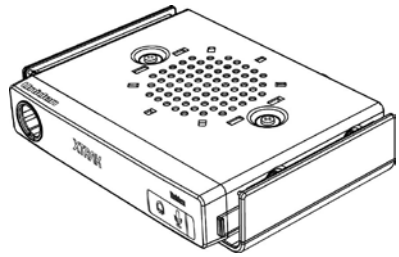
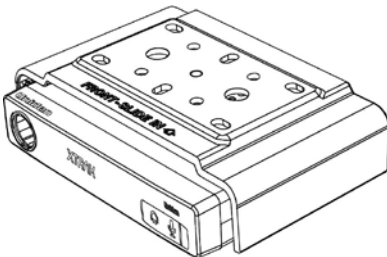

Connecting the Microphone

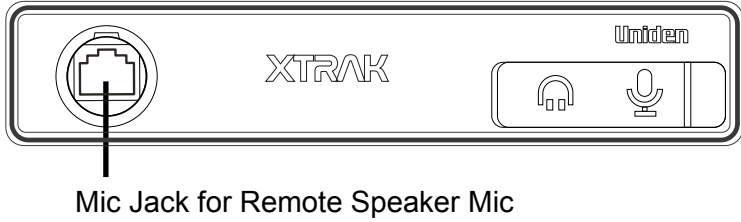

MIC Jack

Before connecting the Microphone Jack decide if you need to use the 2 metre Extension Cable - simply connect the MIC plug into the jack end of the Extension Cable

Push the MIC plug or Extension Cable plug into the MIC jack of the radio until the connection locks into place. Gently tug the MIC or Extension Cable cord to test that the connection is locked. Use the rubber cover which is on the cord to seal the MIC jack entry from dust.

Disconnecting the MIC from the MIC Jack

Pull back the rubber cover and move it down along the cord. Using the flat blade of a screwdriver or similar object carefully push the lock tab of the MIC plug towards the MIC cord and at the same time tug on the MIC cord to draw back the MIC plug.

Mounting the MIC Hanger

The Magnetic MIC Hanger comes assembled so the double sided tape can be applied to the rear side and then applied to a suitable mounting location.

Locate a suitable mounting position.

Remove (peel off) the plastic covering the adhesive tape on the flat area of the MIC Hanger back piece and then press firmly to the mounting position.

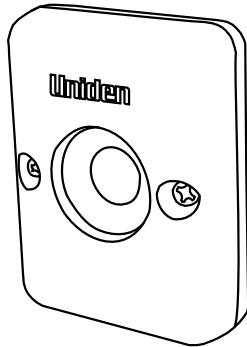

Operation

- See the Controls and Indicators on page 6 for dedicated key functions.
- In addition to the dedicated key functions, many features are available in the MENU.

MENU Order List

01 Squelch	11 Key Beep
02 Duplex	12 Alpha tag
03 Priority Watch	13 Speaker Select
04 Pri/Inst CH1	14 B.light/Dimmer
05 Pri/Inst CH2	15 Replay (RX Rec.)
06 Scan Mode	16 Scramble
07 M.Scan Code	17 Microphone Gain
08 Call Tone	18 Bluetooth App*
09 BCL	19 Bluetooth Audio*
10 Roger Beep	*XTRAK 80 PRO Only

- Each MENU function is described in their respective operations.

To use the MENU

1. Press **[MENU]** and then press **[UP / DOWN]** to highlight a menu option.
2. Press **[MENU]** to select the option.
3. Press **[UP / DOWN]** to highlight a setting option.
4. Press and hold **[MENU]** to store the setting.

Turning on the Power

Press and hold **[POWER]**.

Low-Voltage/High-Voltage Alert

The XTRAK can operate on 12VDC (13.8V) or 24VDC (27.6V) power supply, with the range between 10.2VDC to 28.8VDC.



If the power supply voltage exceeds 30VDC, an alert tone sounds and **HI DC** flashes for 5 seconds. The power source must not exceed 32VDC otherwise permanent damage may occur to your radio, which may not be covered by the manufacturer's warranty.

If the input voltage falls below 10VDC, **LO DC** flashes for 5 seconds. The power turns off automatically if voltage falls below 9.0VDC.

Switch your XTRAK OFF and disconnect it from the power source, before locating the cause of the power supply problem.

Operation

Setting the Auto Squelch Level

The Squelch function is the radio's signal filter. It determines when the radio's speakers turn on, based on the strength of received signals. This avoids background noise and undesired signals constantly coming through the speakers.

The Auto Squelch feature has an off (Sq0) setting and 9 preset squelch levels: It requires no adjustment once set.

- Sq0 (off)** - **squelch is fully open to noise & signals**
This is also the Monitor Mode
- Sq1** - **max sensitivity (min squelch)**
Weak (distant) signals can open the squelch.
- Sq5** - **med sensitivity (med squelch)**
Medium and strong signals can open the squelch.
- Sq9** - **min sensitivity (max/tight squelch)**
Only strong/nearby signals can open the squelch.

Setting the Squelch level from the MENU

1. Press **[MENU]** two times. The squelch setting flashes.
2. Press **[UP / DOWN]** to select a squelch level setting.
3. Press and hold **[MENU]** to store the setting.

Setting the Squelch level by [SQL] Smart Key

When the **[SQL]** Smart Key is set to SQL, press **[SQL]** to increment the squelch one level each press. When the squelch level is maximum the next press cycles back to Sq0 (Monitor mode). The squelch bar is an indication of the increasing squelch levels - one bar equates to 2 squelch increments.



- If Sq0 (open squelch) is selected then MON (monitor) icon flashes.
- Setting a tight squelch may prevent the reception of weak signals.
- High noise areas may still break the squelch.

Monitor Mode

The Monitor mode is the squelch function turned off. Use Monitor mode to quickly check the channel for any weak signals, or if using DCS/CTCSS.

Enable/Disable Monitor Mode by SMART Key

When a SMART key is set to MON, press the assigned SMART key to turn Monitor mode on or off. **MON** will flash on the display when Monitor is on.

Monitor mode is also entered when the SQL level is set to Sq0.

Operation

Selecting a Channel

Press [**UP** / **DOWN**] to select a desired channel.

When the **CB** icon is showing the 80 UHF-CB and any user programmed RX channels will be available for selection or scanning.

The 80 UHF-CB channels are numbered 01-80.

The user programmable RX only channels are numbered 81-180 and only show in the DCS/CTCSS code area, when programmed¹.



¹ Available frequencies & channels are within 400-520MHz Band only in 12.5kHz steps.

For your reference a list of the available channels, corresponding frequencies and guidelines for their use is printed on p.47 - p.49. For Australia, Channels 05 and 35 are reserved for Emergency Calls.

Transmitting & Receiving UHF CB

The XTRAK transmits only on UHF-CB Channels.



For your reference a list of the available channels, corresponding frequencies and guidelines for their use and selection is printed on p.47 - p.49. For Australia, Channels 05 and 35 are reserved for Emergency Calls.

1. Select a desired channel.

Listen to the channel to make sure there is no activity.

2. Hold the microphone approx. 7cm from your mouth.

3. Press the microphone's [**PTT**] button and speak in a normal volume across (not into) the microphone.

The **TX** icon and current **MIC GAIN** level displays while the PTT is pressed.

4. Release the [**PTT**] button to end the transmission and listen for a reply.

For extended range:

- Transmit in Duplex mode, see Using UHF CB Repeater Channels page 15.

For uninterrupted transmission in busy channel areas:

- Transmit & Receive in Master Scan mode, see Master Scan page 24.

Operation

Using UHF CB Repeater Channels

Normal Simplex operation transmits on one particular frequency and receives on that same frequency. If there is a barrier that partially blocks your transmitted signal, the probability of another radio receiving the signal is very slim. Hills, tall buildings, metallic structures,....etc tend to act as a screen between radios.

Simplex Operation without the aid of a Repeater station.

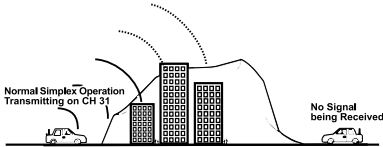

Duplex Operation with the aid of a Repeater Station.

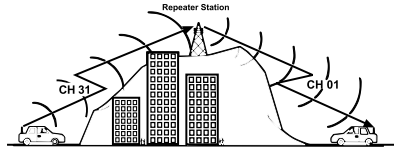

To extend the range of your radio and overcome the shielding effect caused by solid obstructions the Duplex operation transmits on a UHF CB repeater frequency, where a Repeater Station re-transmits your signal on the frequency used in Simplex Operation.

The signal coming from your radio is received by the Repeater Station and is re-transmitted at the same time on another channel. This operation is called “Duplexing”.

For example,

CH01 on Duplex Mode will Receive on CH01 but Transmit on CH31

CH02 on Duplex Mode will Receive on CH02 but Transmit on CH32 etc...

If you transmit on CH01 Duplex mode, you are actually transmitting on CH31 the repeater station down-converts your signal and retransmits on CH01.

Enable / Disable Duplex Mode

Only channels 01-08 and channels 41-48 are available for Duplex.

1. Press **[MENU]**. Press **[UP / DOWN]** until **02 Duplex** is highlighted.
2. Press **[MENU]** to select.
3. Press **[UP / DOWN]** to change the setting between ON or OFF.
4. Press and hold **[MENU]** to save & exit from the menu mode.

The **DUP** icon displays when a selected channel is set to Duplex mode.



NOTE

- Only channels 01-08 and channels 41-48 are available for Duplex.
- Check with your local Retailer for information on available repeaters.
- Check local repeater availability using the XTRAK App (XTRAK 80 PRO only).

Operation

SMART Key Function

INST TRI SQL



The XTRAK has 3 SMART keys which can be programmed (set) to operate the following one-touch functions.

- INST - Instant Channel (CH1, CH2) recall
- TRI - Triple Watch mode on/off
- SQL - Squelch level increment/cycle
- CAL - Call Tone transmit
- EQL - Equaliser level increment/cycle
- MON - Monitor mode on/off
- T.SQ - Tone Squelch Mode enable/disable
- SELC - Make a Selcall (Selective Call)
- PAI - Pair Bluetooth Audio device*

1. Press and hold the SMART key to set the next function. The icon for the function will display. The table below shows which functions are available for each SMART key.



[INST /S]	[TRI]	[SQL]	
INST	TRI	SQL	< Default Setting
CALL	CALL	CALL	
EQL	EQL	EQL	
MON	MON	MON	
PAI*	T.SQ	SELC	

*XTRAK 80 PRO Only

2. Press the SMART key to use the current function.

Operation

Instant Channel

You can set two channels as Instant Priority Channels (CH1 and CH2), which can be recalled at the press of a button. These two channels are also monitored, along with the current channel, when Triple Watch mode is enabled.

Setting the Instant Priority Channel (CH1 or CH2)

By default Instant Priority CH1 is preset to the emergency channel, CH05.
By default Instant Priority CH2 is preset to the emergency channel, CH35.

1. Press **[MENU]**.
2. Press **[UP / DOWN]** key until **04 Pri/Inst CH1** or **05 Pri/Inst CH2** is highlighted.
3. Press **[MENU]** to select. The current CH1 or CH2 channel setting flashes.
4. Press **[UP / DOWN]** to select a desired channel.
5. Press and hold **[MENU]** to save and exit.



If you only wish to have one Instant Priority Channel, then set Instant Priority CH2 to Off.

Recalling the Instant Channel

When the **[INST/S]** SMART key is set to INST;

1. Press **[INST/S]** to recall the Instant Priority CH1
2. Press **[INST/S]** again to recall the Instant Priority CH2 (if CH2 has been set)
3. Press **[INST/S]** again to return to the previous channel.

The **INST** icon displays when showing Instant Priority CH1 or CH2

Operation

Triple Watch (and Dual Watch)

Triple watch will continuously monitor the two Instant Priority Channels (CH1 and CH2) and the current channel for activity.

If Instant Priority CH2 is set to Off, then Triple Watch monitors Instant Priority CH1 and the current channel for activity - this is a Dual Watch. (see Programming the Instant Priority Channel-1/Channel-2, p.17)

When the **[TRI]** SMART key is set to TRI;

1. Press **[TRI]** to switch Triple Watch On/Off.

The **TRI** icon displays when Triple Watch mode is on.



NOTE

- Every 1.5 seconds the Instant channel is monitored for 40 msec.
- Triple watch function stops temporarily when receiving a signal.
- Triple watch function is invalid in Scan mode.

EQL (Equaliser - Voice Enhance Setting)

Choose from 4 different receive audio level settings to provide a natural Voice Enhance for clarity and performance.

When a SMART key is programmed to **EQL**;

1. Press that SMART key to increment/cycle the setting between the 4 levels;

EQL 0: Normal - Standard or FLAT.

EQL 1: Bass - Enhanced low frequencies, sound quality becomes mild and easy to listen to, not causing fatigue.

EQL 2: Midrange - Enhanced midrange frequencies, sound quality becomes clear.

EQL 3: High - Enhanced the high frequencied, sound quality becomes sharp.



NOTE

When a signal is received, except for when in Monitor mode, the current EQL level will display.

Operation

Call Tone

Use the Call Tone function to transmit a three second 'wake-up' ringing tone. The XTRAK is equipped with 10 selectable call tones that can be set in the MENU (08 Call Tone).

Setting the Call Tone

1. Press **[MENU]** and then press **[UP / DOWN]** key until **08 Call Tone** is highlighted.
2. Press **[MENU]** to select.
3. Press **[UP / DOWN]** to change the selection. The call tone chime will sound whenever the selection is changed.
4. Press and hold **[MENU]** to save & exit from the menu mode.

To use Call Tone

When a SMART key is set to CAL;

1. Press that SMART key to transmit the call tone.



• Current regulations require calling tones to be restricted to one transmission per minute. If a second transmission is attempted within one minute then an error tone will sound.

Operation

CTCSS (Continuous Tone Coded Squelch System)

On congested channels use a CTCSS or DCS code to keep your radio speaker silent - unless a signal is received from a radio using the same code you have set for that channel. The code is transmitted when you are pressing PTT on a channel that you have set a CTCSS code on. Share the code with radio users to hear only their transmissions.

When a CTCSS or DCS tone is set for a UHF-CB channel, the CTCSS or DCS tone is displayed in the DCS/CTCSS code area. For channels with the setting of CTCSS OFF, there will be no display in the DCS/CTCSS code area.

1. Press **[UP / DOWN]** to select the desired channel to use CTCSS.
2. Press **[DCS/CTCS]**. The **CTCSS** icon and the current code flashes.
3. Press **[UP / DOWN]** to select the desired CTCSS code from 01 - 50.
4. Press **[DCS/CTCS]** once to store the new setting.

The **CTCSS** icon and code will display for the channel.

To turn off CTCSS (or DCS) select OFF during setting.

DCS (Digital Coded Squelch)

DCS is a digital extension of CTCSS. It provides 104 extra, digitally coded, squelch codes that follow after the 50 CTCSS codes. CTCSS 01-50, followed by DCS 01-104.

1. Follow the steps for setting a CTCSS code.
2. Press **[UP / DOWN]** until a desired DCS code appears.
3. Press **[DCS/CTCS]** to set. The **DCS** icon and code will display for the channel.



CTCSS and DCS is not available on CH 05 and CH 35. For your reference a list of the available channels, corresponding frequencies and guidelines for their use and selection is printed on p.51 - p.53 For Australia, Channels 05 and 35 are reserved for Emergency Calls.

Operation

Scanning

The XTRAK's Scanning feature allows you to search for active channels automatically. There are two main scanning modes;

- Open Scan (O.S)
- Group Scan (G.S)

During SCAN the XTRAK only checks channels or frequencies that are in the SCAN Memory, which are indicated by the **MEM** icon. The XTRAK maintains two SCAN Memories; one for Open Scan (OS) mode and the other for Group Scan (GS) mode, to give you flexibility and allow you to use the radio more effectively.

1. Press **[SCAN]** to start Scanning.
2. The **SCAN** icon flashes during scan.
3. The scan direction can be changed at any time by pressing **[UP / DOWN]**.
4. Press **[SCAN]** to stop Scanning.



NOTE

Master Scan (M.S) and Tone Squelch Scan (T.Sq) are special scan modes which are described separately.

Open Scan (OS) Mode

All UHF-CB, user-programmed extra RX channels have been added to the OS SCAN Memory for convenience. To add/remove channels from OS SCAN Memory, refer to p.23.

Allows continuous scanning of all selected channels. If an active channel is found, scanning will stop on that channel. If the received signal ceases, the unit will wait 3 seconds for the signal to return, otherwise scanning resumes. After transmission in scan mode, the unit will wait 20 seconds for the signal to return, otherwise scanning resumes.

To select the OS Scan Mode:

1. Press **[MENU]** and then press **[UP / DOWN]** key until **06 Scan Mode** is highlighted.
2. Press **[MENU]** to select.
3. Press **[UP / DOWN]** to change the selection to Open Scan.
4. Press and hold **[MENU]** to save & exit from the menu mode.

The **O.S** icon displays.



NOTE

If SCAN is deactivated while on an active channel, the XTRAK will stay on that active channel. If no channels are active, the XTRAK will reinstate the starting channel.

Operation

Group Scan (GS) Mode

GS Mode has CH09 to CH20 in the SCAN Memory by default. Channels must be stored to the GS SCAN Memory before group scan can start. To add/remove channels from GS SCAN Memory, refer to p.23.

Includes the accessory feature Priority Watch which allows you to monitor the Instant Priority Channel (CH1) while scanning (see p.17 for setting Instant Priority Channel (CH1) and p.23 to turn on Priority Watch for Group Scan).

GS Scanning checks the Instant Priority CH1 for activity regularly when Priority Watch is ON.

If the Priority Channel becomes active the radio will stay on that channel for as long as the signal is present. If the received signal ceases, Priority Scanning continues after 3 seconds.

If scanning stops on a channel which is not the Instant Priority Channel, UHF CB Radio will continue monitoring the Instant Priority Channel for activity while listening to the active one.

To select GS Scan Mode:

1. Press **[MENU]** and then press **[UP / DOWN]** to highlight **06 Scan Mode**.
2. Press **[MENU]** to select.
3. Press **[UP / DOWN]** to change the selection to Group Scan.
4. Press and hold **[MENU]** to save & exit from the menu mode.

The **G.S** icon displays.

Operation

Priority Watch for Group Scan

To switch Priority Watch On/Off;

1. Press **[MENU]** and then press **[UP / DOWN]** to highlight **03 Priority Watch**.
2. Press **[MENU]** to select the option.
3. Press **[UP / DOWN]** to highlight On or Off.
4. Press and hold **[MENU]** to store the setting.



If SCAN is deactivated while it is tuned to an active channel, the XTRAK will stay on that active channel. If none of the channels are active, the XTRAK will reinstate the scan start channel.



If OS/GS Scanning is initiated when there are no channels programmed in OS/GS memory, an error tone will be heard and scanning will not start (see Add/Remove Channels from SCAN Memory, p.23).

Add/Remove Channels from SCAN Memory

Select OS/GS Scanning Mode. Select the channel you want to store.

Press and hold **[MEM]**. The **MEM** icon appears and two beep tones sound. To remove the channel from SCAN memory, press and hold **[MEM]** once more. The **MEM** icon disappears.

Operation

Master Scan (Uninterrupted Transmit & Receive)

Master Scan is a Transmit & Receive mode, using scan, that will allow continual communication across congested channels.

Use Master Scan with other radios that are also set up to the same Master Scan settings. Master Scan will not work on its own or if its settings are different from other radios using Master Scan.

The two settings all radios in your Master Scan network must share are;

- Scanning the same group of channels from the Group Scan (GS) memory
- Using the same CTCSS/DCS code

For your convenience, by default;

- Channels 09-20 are stored into GS Memory and
- CTCSS 01 is set as the Master Scan subcode.

By scanning only group channels, radios in the network will be able to detect and receive group transmissions - continual communication without interruption.

When transmitting in this mode, the radio switches to an unused group channel if it detects another signal with no CTCSS/DCS code, or the wrong code, on the channel last used by the group. In this way, all group users will be able to have continual communication to or from other users.

The GS memory can be changed, channel by channel, if desired - but for Master Scan to work effectively each radio in the group must have the same channels in its GS memory.

To add/remove channels from G.S SCAN Memory, refer to page 23.



RX only Channels (CH22, CH23, CH61, CH62 and CH63), Emergency Channels (CH05, CH35), User Programmable RX Channels (CH81 to CH180) and Fire (& Ambulance) channels group will not be included in Master Scan Mode even though stored into GS Memory. Also channels for which Duplex Setting is On will be skipped in Master Scan Mode.

Operation

Setting up Master Scan Mode

First, Set the SCAN mode to a Master Scan channel group (GS memory)

M.Scan:	Master Scan with the current Group Scan (GS) memory.
M.Scan Preset 1:	Master Scan with CH 09-20 loaded into GS memory.
M.Scan Preset 2:	Master Scan with CH 21-30, 39, 40 loaded into GS memory.
M.Scan Preset 3:	Master Scan with CH 49-60 loaded into GS memory.
M.Scan Preset 4:	Master Scan with CH 61-70, 79, 80 in GS memory.

1. Press **[MENU]** and then use **[UP / DOWN]** to highlight **06 Scan Mode**.
2. Press **[MENU]** to select.
3. Press **[UP / DOWN]** to change the setting to a Master Scan (M.Scan) option.
4. Press and hold **[MENU]** to save & exit from the menu mode.



If you choose to use MASTER SCAN with the current GS channel memory, you need to make sure all other radios in your network have the same channels stored in GS memory. The Presets (1-4) make it easier for all radios to select a common setting.

Second, Select a Master Scan subcode

1. Press **[MENU]** and then use **[UP / DOWN]** to highlight **07 M.Scan Code**.
2. Press **[MENU]** to select.
3. Press **[UP / DOWN]** to select a CTCSS or DCS code.
4. Press and hold **[MENU]** to save & exit from the menu mode.



If a button is not pressed within 10 seconds the UHF CB Radio will automatically exit the Menu Mode.

Using Master Scan

Once Master Scan has been set up for your radio and other radios in your network, simply press **[SCAN]** to enable or disable M.SCAN. The **SCAN** icon flashes in this mode.

When SCAN is enabled for Master Scan, simply use the radio (Transmit and Receive) as you would normally. Using Master Scan should feel like using a normal single channel.

Operation

Busy Channel Lockout

If the channel is already in use, you can prevent the UHF CB Radio from transmitting. This is particularly important when using CTCSS/DCS.

1. Press **[MENU]** and then use **[UP / DOWN]** to highlight **09 BCL**.
2. Press **[MENU]** to select.
3. Press **[UP / DOWN]** to select a On or Off.
4. Press and hold **[MENU]** to save & exit from the menu mode.



If a button is not pressed within 10 seconds the XTRAK will automatically exit the Menu Mode.

Roger Beep

1. Press **[MENU]** and then use **[UP / DOWN]** to highlight **10 Roger Beep**.
2. Press **[MENU]** to select.
3. Press **[UP / DOWN]** to select a On or Off.
4. Press and hold **[MENU]** to save & exit from the menu mode.



If a button is not pressed within 10 seconds the XTRAK will automatically exit the Menu Mode.

Operation

Key Beep On/Off

1. Press **[MENU]** and then use **[UP / DOWN]** to highlight **11 Key Beep**.
2. Press **[MENU]** to select.
3. Press **[UP / DOWN]** to select a On or Off.
4. Press and hold **[MENU]** to save & exit from the menu mode.



If a button is not pressed within 10 seconds the UHF CB Radio will automatically exit the Menu Mode.

Alpha Tag

The SELCALL IDs and Extra Receive Channels have the option of displaying a name (Alpha Tag) instead of the ID or frequency. Set Alpha Tag to ON to display the name if it has been programmed.

1. Press **[MENU]** and then use **[UP / DOWN]** to highlight **12 Alpha Tag**.
2. Press **[MENU]** to select.
3. Press **[UP / DOWN]** to select a On or Off.
4. Press and hold **[MENU]** to save & exit from the menu mode.



If a button is not pressed within 10 seconds the UHF CB Radio will automatically exit the Menu Mode.

Operation

Speaker Select

Use this to set which speaker/s to enable.

- Base Only
- Remote Only
- Dual Speaker

1. Press **[MENU]** and then use **[UP / DOWN]** to highlight **13 Speaker Select**.
2. Press **[MENU]** to select.
3. Press **[UP / DOWN]** to select an option.
4. Press and hold **[MENU]** to save & exit from the menu mode.



When an optional External Speaker is connected to the Ext.Sp. jack of the base, it substitutes for the Base speaker, which becomes muted.



If a button is not pressed within 10 seconds the UHF CB Radio will automatically exit the Menu Mode.

Key Backlight / Display Dimmer

1. Press **[MENU]**, then use **[UP / DOWN]** to highlight **14 B.Light/Dimmer**.
2. Press **[MENU]** to select.
3. Press **[UP / DOWN]** to select a CTCSS or DCS code.
4. Press and hold **[MENU]** to save & exit from the menu mode.



If a button is not pressed within 10 seconds the UHF CB Radio will automatically exit the Menu Mode.

Operation

Voice Scramble

The scramble feature is a voice inversion function that provides additional privacy with your communication.

Two scramble frequencies are available to choose from; *3300 Hz* and *2952 Hz*. Make sure other radios you are communicating with are using the same scramble frequency.

1. Press **[MENU]**, then use **[UP / DOWN]** to highlight **16 Scramble**.
2. Press **[MENU]** to select.
3. Press **[UP / DOWN]** to select an option.
4. Press and hold **[MENU]** to save & exit from the menu mode.



For safety purposes Scramble is invalid on channel 5, 11, 22, 23 and 35.



If a button is not pressed within 10 seconds the UHF CB Radio will automatically exit the Menu Mode.

Microphone Gain

The microphone gain of the XTRAK can be adjusted across 10 levels. Level 1 is minimum sensitivity. Level 10 is maximum sensitivity.

Increase the gain if you are a soft speaker or reduce the gain if you normally speak loudly.

1. Press **[MENU]**, then use **[UP / DOWN]** to highlight **17 Microphone Gain**.
2. Press **[MENU]** to select.
3. Press **[UP / DOWN]** to select an option.
4. Press and hold **[MENU]** to save & exit from the menu mode.

Operation - Special Features

Instant Replay / Receiver Record

The Instant Replay feature automatically records up to 6 minutes of received signals which can be instantly replayed (through the speaker) by pressing **[REPLAY]**.

Instant Replay automatically records receive signals in the normal channel mode and SCAN mode.

Press **[REPLAY]** at anytime to;

1. Playback the most recent received signal.
OR
2. Playback the most recent recorded signal in the replay buffer (if Instant Replay automatic receive record was turned Off, see Turning Instant Replay On/Off below).

During playback the display shows REPLAY and the number of the currently playing recording.

After the most recent received signal has been played back, a long confirmation tone sounds and the radio returns to the previous mode.

During playback older recordings can be accessed by pressing /to skip forward/back between recordings stored within the buffer. The record number indicates which discrete recording is currently being replayed.



- Received signals shorter than 500ms are not recorded.
- Automatic recording of receive signal(s) is temporarily suspended during Instant Replay playback.
- Older recordings are automatically overwritten when new recordings are stored.
- Most received communications are short and the record buffer may contain several recordings.
- Instant Replay does not record when in monitor mode (Sq0 setting in normal channel mode).
- Transmissions (TX) are not recorded.

Turning Instant Replay On/Off

Instant Replay is ON by default. The R|> icon displays to indicate Instant Replay automatic record is On. R|X icon displays when Instant Replay is Off.

1. Press **[MENU]** and then use **[UP / DOWN]** to highlight **15 Replay(RX Rec.)**.
2. Press **[MENU]** to select.
3. Press **[UP / DOWN]** to select an option.
4. Press and hold **[MENU]** to save & exit from the menu mode.

Operation - Special Features

100 User Programmable RX Channels

The XTRAK has 100 receive only channels (CH 81 to CH 180) which can be programmed with frequencies ranging from 400-520MHz (in 12.5kHz steps).

The extra RX channels only appear, as part of the CB channel bank, when a frequency has been programmed to a channel. There are two ways to programme RX channels;

1. If you know the frequency you may manually programme it to a channel.
2. Search the 400-520 MHz frequency range using SCAN and store found frequencies to the channel.

Furthermore, the RX channels can be Alpha Tagged (given a name) if desired.



Managing the 100 RX only channels can also be done within the XTRAK App (XTRAK 80 PRO only).

Programme a RX Only Channel

The XTRAK can store up to 100 extra RX channel/frequencies with the 400 MHz-520 MHz range in 12.5KHz steps.

1. Press and hold **[MENU]**. The lowest available empty RX channel will flash.
2. Press **[UP / DOWN]** if you wish to select another RX channel.
3. Manually enter a frequency:
 - i). Press **[REPLAY]** to begin the frequency edit. The MHz digit range flashes.
 - ii). Use **[TRI]** or **[SQL]**
- to shift between MHz range (**000.0000**) and kHz range (**000.0000**).
 - iii). Press **[UP / DOWN]**
- to select a MHz (in 1MHz steps) & kHz (in 12.5kHz steps) value.

OR

Search for a frequency using SCAN:

- i). Press **[SCAN]** to start scanning. The XTRAK will begin searching frequencies between 400 MHz and 520 MHz in 12.5kHz steps.
The scan direction can be changed at any time by pressing **[UP / DOWN]**.
- ii). If an active frequency channel is found, scanning will stop on that frequency.
To skip, press **[UP / DOWN]** to continue scanning.
- iii). When a desired frequency is found, press **[SCAN]** to exit from frequency scan.

Operation - Special Features

4. Press **[REPLAY]** to move to Alpha Tag selection. A cursor flashes in the 1st alpha position. If you do not wish to name the channel then move on to step 5.
 - i). Press **[UP / DOWN]** to select the desired alpha character.
 - ii). Use **[TRI]** or **[SQL]** to shift between cursor positions.
5. When finished, press **[REPLAY]**. The RX channel flashes.
If you wish to select another RX channel to edit, use **[UP / DOWN]**.

6. Press and hold **[MENU]** to exit programming mode.
A long confirmation tone sounds to indicate the new channel is programmed.



To delete an extra RX channel, edit the channel frequency to 000.0000 and exit programming mode.



Managing the 100 RX only channels can also be done within the XTRAK App (XTRAK 80 PRO only).

Operation - Special Features

Selective Calling (SELCALL)

Selective Calling (Selcall) is a special Sequential Tone Squelch System that allows the user to receive/transmit calls selectively from/to an individual or group, on a shared busy channel. Therefore Selcall is a group feature used by groups with similarly set up radios.

The XTRAK has a Selective Calling system. Exceptional features, like 10 Selcall ID Memories, Receiver Quieting, Tone Squelch Scanning, Tone and Group Calling make the XTRAK superior to other transceivers in its class.

Make a Selcall (Tone Calling) - Allows you to selectively call another radio. Up to 10 Selcall IDs can be stored for frequently called radios.

Group Calling Capability - Transmits Group Calls.

Receiver Quieting (TSQ - Tone Squelch)

When activated on individual UHF-CB channels (except for emergency CH05 and CH35), it automatically mutes the receiver audio circuit of the radio. It will stay in this Quiet mode as long as the Selcall tone code (Selcall ID) required to open the muting circuit is not received.

Tone Squelch Scanning - Scans only TSQ tone squelched Channels.

Call Alarm - When a received code matches to your Selcall ID, an alarm (CAAlert) will be emitted informing you that a caller is on the channel.

Programme (Set) the Selcall ID for your Radio

The radio Selcall ID is the ID other users will identify as being your radio. It is set in the SELCALL settings menu as follows:

IMPORTANT: The **[SQL]** smart key must be set to SELC to access this feature.

1. Switch Off the Power.
2. Press and hold **[POWER]** and **[SQL]**. The XTRAK will turn on with the SELCALL Settings Menu (no tone will sound). **Cd** displays to indicate the Call ID setting (factory default ID is 00000).
3. Press **[SCAN]** to begin the Selcall ID edit. The 5th digit of the ID flashes.
 - i). Press **[UP / DOWN]** to select a desired ID number, per digit.
 - ii). Use **[VOL +]** or **[VOL -]** to shift between digits.
A 6th digit (for 6 tone Selcall) is available and indicated by a ' _ '.
4. Press **[SCAN]** to exit the ID setting mode.
5. Press and hold **[TRI]** to exit programming mode. A long confirmation tone sounds.
OR
Press and hold **[POWER]** to power off to exit programming mode.

Operation - Special Features

Storing Selcall IDs of Other Users to the ID Memory



- Up to 10 ID memories can be stored.
- If you expect to make calls to radios not stored in the ID memory then leave memory ID 1 blank for manual ID entry at the time of the call.
- Managing the Selcall ID memory can also be done within the XTRAK App (XTRAK 80 PRO only).

IMPORTANT: The **[SQL]** smart key must be set to **SELC** to access this feature.

1. Press and hold **[SQL]** (SELC).
The Selcall ID memory will open and the first entry (1 of 10) flashes.
2. Press **[UP / DOWN]** to select a desired memory number to edit.
3. Press **[SCAN]** to begin the ID edit. The 5th digit of the ID flashes.
 - i). Press **[UP / DOWN]** to select the desired ID digit.
 - ii). Use **[VOL +]** or **[VOL -]** to shift between digits.
A 6th digit (for 6 tone Selcall) is available and indicated by a ' _ '.
4. When the desired ID is entered press **[SCAN]** to move to Alpha Tag selection.
A cursor flashes in the 1st alpha position. The default alpha tag is blank - displays as No Name. If you do not wish to name the ID then skip to step 9.
 - i). Press **[UP / DOWN]** to select the desired alpha character.
 - ii). Use **[VOL +]** or **[VOL -]** to shift between cursor positions.
5. When finished press **[SCAN]**. A confirmation tone sounds to indicate the ID is programmed. The memory number flashes to enable selection for programming of next memory if desired.
6. Press and hold **[ENTER]**, or wait for 10sec, to exit programming mode.

Operation - Special Features

Making a Selcall Call (Tone Calling)

Tone Calling allows you to selectively call other radios who have also setup Selcall.

For convenience, the Selcall ID of the radio you are going to call should be in the Selcall ID memory (see Storing Selcall IDs of other users to the ID Memory p.39).

If not then the Selcall ID can be manually entered for this call.

IMPORTANT:

Make sure the **[TRI]** SMART key is programmed to **T.SQ**

Make sure the **[SQL]** SMART key is programmed to **SELC**

To Call:

1. Select the channel that you and your group agreed to use for Selective Calling.
2. Press and hold **[SQL]**. A double beep tone will sound and the last stored ID or last transmitted ID will be displayed.
3. Use **[UP / DOWN]** to select the desired Selcall ID.

If the desired Selcall ID is not stored in the ID memory you can manually enter the ID as follows;

- i). Press **[SCAN]** to begin ID edit. The 5th digit of the ID flashes.
- ii). Press **[UP / DOWN]** to select the desired ID.
- iii). Use **[VOL +]** or **[VOL -]** to shift between digits.
A 6th digit (for 6 tone Selcall) is available and indicated by a ' _ '.

4. Press **[SQL]** to transmit the Selcall.

TX-CAL will display when transmitting the Selcall.

An acknowledge tone coming from the called radio will be received if you have successfully made contact. The acknowledge tone for the XTRAK is a succession of three low tone beeps.

Operation - Special Features

TSQ (Tone Squelch Mode - Receiver Quiet)

Puts the receiver in the QUIET mode (also known as the Tone Squelch (TSQ) mode) for the selected channel. When activated, the transceiver prevents any unwanted conversations in the channel from being heard unless the call is specifically directed to you and the Selcall ID required to open the QUIET condition has been received.



Under this condition, **PTT** is temporarily disabled. If you wish to use the same Channel for normal communication, simply remove the channel from QUIET mode.

Activate/Deactivate Tone Squelch (TSQ) on a Channel

When the **[TRI /S]** SMART key is programmed to **T.SQ**

1. Use **[UP / DOWN]** to select the channel you want to put in or take out of 'QUIET' mode.
2. Press **[TSQ]**. A beep will sound and the **T.Sq** icon appears on or disappears from the display.

Scanning Tone Squelched Channels

When the **[TRI]** SMART key is programmed to **T.SQ**

If you are using two or more Channels in the TSQ mode, you can monitor all of these Channels for selective calls by using the TSQ scanning feature.

To use this feature start the TSQ Scan by pressing **[TSQ]** during Open Scan or Group Scan or Master Scan.

Unlike Normal Scanning, TSQ scans and checks detected signals for Selcall information. If this information is not found, TSQ Scanning resumes. When a call is received during TSQ Scanning, XTRAK follows the same response as when receiving a call on a Tone Squelch Channel. It differs only in the following ways:

1. If the call is not answered within 20 seconds, TSQ Scanning resumes.

The **CAL** icon remains on the LCD display.

To look for the Channel where the CALL is received.

- i). Cancel TSQ Scanning by pressing **[SCAN]**.
- ii). Using **[UP / DOWN]** , browse through the TSQ Channels. The CAL indicator marks the Channel where the Call is received.

Operation - Special Features

2. When answered, TSQ Scanning is automatically deactivated. The Channel is removed from the QUIET Operating Mode.

To deactivate TSQ Scanning:

- i). Press **[TRI]**.
The unit returns to Normal Scanning Mode.
- ii). Press **[SCAN]**.
The whole scanning operation is cleared.
- iii). When a Selcall is received, press **PTT**.



The chance of receiving and decoding Selcalls effectively during TSQ Scanning can be increased in many different ways. You can either decrease the number of channels to be scanned thus increasing the scanning speed – or – change some of the Selcall parameters (refer to ‘SELCALL Settings Menu, p39’).

Receiving a Selcall

While in TSQ mode, when XTRAK receives a code matching your Selcall ID, it will perform the following operations:

- a) Automatically responds to the caller by transmitting Acknowledge Tones.
- b) Informs you that a caller is on the Channel by emitting a CALL ALARM (Default Alarm Setting: four successive beeps in a regular interval for 10 seconds. Refer to p.46, ‘Alarm Mode’ for other alarm settings) and displays the CAL icon.
- c) Flashes the TSQ icon for about 20 seconds allowing you to use the PTT button. If you are not able to respond within the 20 second period, TSQ icon stops flashing and ‘QUIET’ mode resumes.



The XTRAK can decode a Selcall call even though not in ‘QUIET’ mode.

Operation - Special Features

Group Calling

The XTRAK has the capability to respond to Group Calling and to transmit Group Calling Codes.

Group Calling allows you to call members of your group simultaneously. However, to do this, you need to follow a certain format (see below) when programming your TX Selcall ID.

Selcall ID Format for Group Calling

To call	Transmitter SELCALL ID
10 radios	[X] [X] [X] [X] [A]
100 radios	[X] [X] [X] [A] [A]
1000 radios	[X] [X] [A] [A] [A]
10000 radios	[X] [A] [A] [A] [A]

where: [X] is a common Selcall ID prefix of your group
- and - [A] is the CCIR Assigned Group Tone Code

Example:

If one group comprises 10 members with Selcall IDs the ID numbers could be as follows:

Group ID #	Individual ID#
[1] [2] [3] [4]	[0]
[1] [2] [3] [4]	[1]
[1] [2] [3] [4]	[2]
[1] [2] [3] [4]	[3]
to -	
[1] [2] [3] [4]	[9]

all in TSQL mode at CH20

If someone transmits ID 1234A on CH20, all of the above units will open their Tone Squelched Receiver.

Group Calls and ordinary Selcalls can be differentiated in the following manner:

Group Call - Low tone beeps
Ordinary Selcall - High tone beeps

Operation - Special Features

SELCALL Settings Menu

To enter the Selcall Settings Menu

1. Switch Off the Power.
2. Press and hold **[POWER]** and **[SQL]**.
The SELCALL Settings Menu will display (no tone will sound).
3. Press **[VOL +]** or **[VOL -]** to change the Selcall setting between the following:

Cd	Radio's SelCall ID
01	Group Call Mode
AL	Alarm Mode
LT	Lead-in Tone
Ld	Lead-in Delay
Pd	Tone Period

Tone Period (Pd)

Tone period is the duration of one tone in a Selcall ID sequence. The setting of this parameter depends on the type of application. On long distance communications, for example: where the signal strength of the transmitted information is greatly reduced and affected by noise, it is advisable to use a longer Tone Period. A long Tone Period gives the decoder more time and information to check and evaluate the code.



However, be sure that all the radios in your group use the same Tone Period setting. Otherwise you will not be able to selectively call one another.

The XTRAK allows you to select which Tone Period is best for you. The three most commonly used tone settings (40,70 or 100 mSec) are available. With the freedom to change this parameter, you can easily adapt to the existing system in your group without the inconvenience of having the unit serviced by the dealer.

1. Open the Selcall Settings Menu and press **[VOL +]** or **[VOL -]** to select the Tone Period setting - which is indicated on the display as Pd.
2. Press **[SCAN]** to edit the setting. The current setting flashes.
3. Press **[UP / DOWN]** to select the desired tone period from 40ms, 70ms or 100ms.
4. Press **[SCAN]** to exit the setting.
5. Press and hold **[TRI]** to save and exit programming mode. A long confirmation tone sounds. OR,
Press and hold **[POWER]** to power off to exit programming mode.

Operation - Special Features

Lead-in Delay (Ld)

Lead-in delay is a Selcall transmission parameter that 'wakes-up' and helps the receiver of the other radio to lock onto the incoming signal. Each time a Selcall ID is transmitted, the Lead-in Delay attaches itself to the beginning of the code sequence and causes the transmitter to be on for a longer period prior to the code transmission. This makes for a stronger communication link between the transmitter and the other receiver.

One major advantage to having the longer Lead-in Delay is when selectively calling another radio via a repeater station. A longer Lead-in Delay helps to stabilise both the communication link from your radio to the repeater station and from the repeater station to the other radio.

Lead-in Delay Programming

1. Open the Selcall Settings Menu and press **[VOL +]** or **[VOL -]** to select the Lead-in Delay setting - which is indicated on the display as Ld.
2. Press **[SCAN]** to edit the setting. The current setting flashes.
3. Press **[UP / DOWN]** to select the desired Lead-in delay period from; 500ms, 1000ms, 2000ms, 3000ms or 4000ms.
4. Press **[SCAN]** to exit the setting.
5. Press and hold **[TRI]** to save and exit programming mode.
OR Press and hold **[POWER]** to power off to exit programming mode.

Lead-in Tone (LT)

The Lead-in Tone, when programmed, 'rides' on the Lead-in Delay. Hence, when transmitting a Selcall ID, a continuous tone will be heard for the duration of the Lead-in Delay. The main purpose of the Lead-in Tone is to increase the probability of contact between your unit and another radio when TSQ Scanning.

1. Open the Selcall Settings Menu and press **[VOL +]** or **[VOL -]** to select the Lead-in Tone setting - which is indicated on the display as LT.
2. Press **[SCAN]** to edit the setting. The current setting flashes.
3. Press **[UP / DOWN]** to select the desired Lead-in Tone.



• If you want to remove the Lead-in Tone choose the space [_] Bar.

4. Press **[SCAN]** to exit the setting.
5. Press and hold **[TRI]** to save and exit programming mode.
OR Press and hold **[POWER]** to power off to exit programming mode.

Operation - Special Features

Alarm Mode (AL)

When a received code matches to your receiver Selcall ID the XTRAK will respond based on the Call Alarm mode.

Call Alarm - Auto mode (Default)

- a) Transmit an Acknowledge tone to the Caller.
- b) Emit CALL Alarm for 10 seconds only.
- c) Resume Quiet condition automatically after 20 seconds if the call is not answered.
- d) The Unit will start decoding again when the 20 second period elapsed and the call remained unanswered.

Call Alarm - Continue mode

- a) Transmit an Acknowledge Tone to the Caller.
- b) Initially an alarm of four successive beeps is emitted for 20 seconds and then two successive beeps every four seconds continuously unless answered.
- c) The Quiet Condition is never resumed.
- d) The Unit continues to check if incoming codes have your Receiver Selcall ID even though the Quiet Condition is already opened. When detected, it will send an acknowledge Tone to the caller and then resets the Call Alarm.



For both of the above mentioned modes, transmission by using the PTT button is possible when the **TSQ** icon is flashing.

1. Open the Selcall Settings Menu and press **[VOL +]** or **[VOL -]** to select the Alarm mode setting - which is indicated on the display as AL.
2. Press **[SCAN]** to edit the setting. The current setting flashes.
3. Press **[UP / DOWN]** to select the desired Alarm mode from AUTO or CONT.
4. Press **[SCAN]** to exit the setting.
5. Press and hold **[TRI]** to save and exit programming mode.
OR Press and hold **[POWER]** to power off to exit programming mode.

Group Call Mode (01/02)

The Group Tone period can be adjusted to increase the ability to identify group calls. Group 01 mode sets the tone period to 1 tone period (default). Group 02 mode sets the first group tone period to 3 tone periods.

1. Open the Selcall Settings Menu and press **[VOL +]** or **[VOL -]** to select the Group Call mode setting - which is indicated on the display as GROUP.
2. Press **[SCAN]** to edit the setting. The current setting flashes.
3. Press **[UP / DOWN]** to select the desired Group Call mode from 01 or 02.
4. Press **[SCAN]** to exit the setting.
5. Press and hold **[TRI]** to save and exit programming mode.
OR Press and hold **[POWER]** to power off to exit programming mode.

Operation - Special Features

Bluetooth APP (*XTRAK 80 PRO Only*)

Through the built-in Bluetooth feature the XTRAK 80 PRO works with the free XTRAK App, available on the Apple Store for iOS smartphones and the Play Store for Android smartphones. Search for the XTRAK App by Uniden. User instructions for the app are embedded in the app.

Installing XTRAK App on your smartphone and connecting your smartphone to your radio over bluetooth allows you to share your location, even without mobile phone service. In addition, it offers recording tracks and controlling the radio settings from the convenience of your smartphone.

The instructions below are only a brief introduction as all instructions are provided within the XTRAK App.

Turn the Bluetooth App setting On when you are ready to connect with a compatible smartphone running the XTRAK App.

1. Press **[MENU]**, then use **[UP / DOWN]** to highlight **18 Bluetooth App**.
2. Press **[MENU]** to select.
3. Press **[UP / DOWN]** to select On or Off.
4. Press and hold **[MENU]** to save & exit from the menu mode.

The 1st Bluetooth signal icon will flash indicating awaiting pairing/connection with a compatible smartphone running the XTRAK App, and will stay steady after pairing/connection.

Once radio and smartphone are paired, re-pairing happens automatically as long as Bluetooth App on the radio is turned on.



This feature is available on the XTRAK 80 PRO only and requires a smartphone installed with the XTRAK App.

The XTRAK App is available on the Apple Store for iOS smartphones and the Play Store for Android smartphones.

The Bluetooth App feature enables data transmissions, it does not enable audio transmission from phone to radio or vice versa

Operation - Special Features

Bluetooth AUDIO (*XTRAK 80 PRO Only*)

Use this setting to connect the XTRAK 80 PRO to compatible Bluetooth devices for audio output - IE: divert the XTRAK 80 PRO audio from the Base & Remote MIC speakers to the compatible Bluetooth device, such as a compatible BT earpiece/speakers.

Before turning the Bluetooth Audio setting On, first set the **[INST /S]** Smart key to PAI. Press and hold **[INST /S]** repeatedly until PAI appears on the display as the Smart key function.

Enable Bluetooth Audio

1. Press **[MENU]**, then use **[UP / DOWN]** to highlight **19 Bluetooth Audio**.
2. Press **[MENU]** to select.
3. Press **[UP / DOWN]** to select On or Off.
4. Press and hold **[MENU]** to save & exit from the menu mode.

The 2nd Bluetooth signal icon will flash indicating awaiting pairing or connection, and will stay steady after pairing/connection.

Pair/Connect to a Compatible Bluetooth audio device.

1. On the compatible bluetooth audio device, initiate pairing.
2. Press **[INST /S]**, when the Smart key is set to PAI (Pair).



Compatible with Bluetooth 5.0 devices.

SELCALL Tone Frequency List

Tone No.	Tone Frequency (Hz)	Tone No.	Tone Frequency (Hz)
0	1981	8	1747
1	1124	9	1860
2	1197	A (Group)	2400
3	1275	B	930
4	1358	C	2247
5	1446	D	991
6	1540	E (Repeat)	2110
7	1640	F	1055

CTCSS Codes Table

Code No.	Frequency (Hz)	Code No.	Frequency (Hz)
"oF"	OFF	26	162.2
1	67.0	27	167.9
2	71.9	28	173.8
3	74.4	29	179.9
4	77.0	30	186.2
5	79.7	31	192.8
6	82.5	32	203.5
7	85.4	33	210.7
8	88.5	34	218.1
9	91.5	35	225.7
10	94.8	36	233.6
11	97.4	37	241.8
12	100.0	38	250.3
13	103.5	39	69.4
14	107.2	40	159.8
15	110.9	41	165.5
16	114.8	42	171.3
17	118.8	43	177.3
18	123.0	44	183.5
19	127.3	45	189.9
20	131.8	46	196.6
21	136.5	47	199.5
22	141.3	48	206.5
23	146.2	49	229.1
24	151.4	50	254.1
25	156.7		

DCS Codes Table

Code No.	DCS Code (Octal)	Code No.	DCS Code (Octal)	Code No.	DCS Code (Octal)
1	023	36	223	71	445
2	025	37	225	72	446
3	026	38	226	73	452
4	031	39	243	74	454
5	032	40	244	75	455
6	036	41	245	76	462
7	043	42	246	77	464
8	047	43	251	78	465
9	051	44	252	79	466
10	053	45	255	80	503
11	054	46	261	81	506
12	065	47	263	82	516
13	071	48	265	83	523
14	072	49	266	84	526
15	073	50	271	85	532
16	074	51	274	86	546
17	114	52	306	87	565
18	115	53	311	88	606
19	116	54	315	89	612
20	122	55	325	90	624
21	125	56	331	91	627
22	131	57	332	92	631
23	132	58	343	93	632
24	134	59	346	94	654
25	143	60	351	95	662
26	145	61	356	96	664
27	152	62	364	97	703
28	155	63	365	98	712
29	156	64	371	99	723
30	162	65	411	100	731
31	165	66	412	101	732
32	172	67	413	102	734
33	174	68	423	103	743
34	205	69	431	104	754
35	212	70	432		

This page intentionally blank

UHF-CB Channel Guidelines

Always listen on a channel (or observe the receive signal level meter) to ensure it is not already being used before transmitting.

Channels 5 and 35 are used for emergency channels.

CTCSS, DCS, TSQ and SELCALL will not operate on these channels.

Please follow these guidelines for channel use in Australia:

- Channels 05 and 35 are Emergency Channels.
- Channel 11 is a Calling Channel.
- Channels 22 and 23 are for telemetry and telecommand applications, channels 61, 62 and 63 are for future use and TX is inhibited on these channels.



General communication is accepted on all other channels with these guidelines:

- Channel 40 - road channel (Australia).
- Channels 01-08 (and 31-38), and Channels 41-48 (and 71-78) are repeater channels.

Important information - 80 Channel UHF-CB channel expansion

To provide all users additional channel capacity within the UHF-CB Band. The ACMA will change the majority of the current wideband 40 channel use to narrowband channel use. This allows for additional channels to be added, up to 80 Channels.

This simply means that the new narrowband radio you have purchased will have more channels than older radios. Please refer to the guidelines above and the channel chart for further channel information.

A list of currently authorised channels can also be obtained from the ACMA website in Australia and the MBIE website in New Zealand.

Interference / Poor Audio



When a new narrowband radio receives a signal from an older wideband radio the speech may sound loud - however the radio's built-in AVS (Automatic Volume Stabilizer) circuitry will detect and manage incoming audio to comparable levels.

Narrowband radios operating on CH41 - CH80 may encounter interference from a nearby wideband radios transmitting on high power on an adjacent channel (frequency).

When an older wideband radio receives a signal from a new narrowband radio the speech may sound quiet - the wideband radio user simply adjusts their radio volume for best performance.

The above situations are not a fault of the radio but a symptom of mixed wideband and narrowband radios in current use. It is expected that as older wideband radios are phased out this issue will be eliminated.

UHF-CB Channels and Frequencies

CH No.	Simplex Mode Transmit / Receive Frequency (MHz)	Duplex Mode Transmit Frequency (MHz)	CH No.	Simplex Mode Transmit / Receive Frequency (MHz)
1	476.425	477.175 (CH31)	21	476.925
2	476.450	477.200 (CH32)	22	476.950 (RX only)
3	476.475	477.225 (CH33)	23	476.975 (RX only)
4	476.500	477.250 (CH34)	24	477.000
5	476.525	477.275 (CH35)	25	477.025
6	476.550	477.300 (CH36)	26	477.050
7	476.575	477.325 (CH37)	27	477.075
8	476.600	477.350 (CH38)	28	477.100
9	476.625		29	477.125
10	476.650		30	477.150
11	476.675		31	477.175
12	476.700		32	477.200
13	476.725		33	477.225
14	476.750		34	477.250
15	476.775		35	477.275
16	476.800		36	477.300
17	476.825		37	477.325
18	476.850		38	477.350
19	476.875		39	477.375
20	476.900		40	477.400

UHF-CB Channels and Frequencies

CH No.	Simplex Mode Transmit / Receive Frequency (MHz)	Duplex Mode Transmit Frequency (MHz)	CH No.	Simplex Mode Transmit / Receive Frequency (MHz)
41	476.4375	477.1875 (CH 71)	61	future use 476.9375 (RX only)
42	476.4625	477.2125 (CH 72)	62	future use 476.9625 (RX only)
43	476.4875	477.2375 (CH 73)	63	future use 476.9875 (RX only)
44	476.5125	477.2625 (CH 74)	64	477.0125
45	476.5375	477.2875 (CH 75)	65	477.0375
46	476.5625	477.3125 (CH 76)	66	477.0625
47	476.5875	477.3375 (CH 77)	67	477.0875
48	476.6125	477.3625 (CH 78)	68	477.1125
49	476.6375		69	477.1375
50	476.6625		70	477.1625
51	476.6875		71	477.1875
52	476.7125		72	477.2125
53	476.7375		73	477.2375
54	476.7625		74	477.2625
55	476.7875		75	477.2875
56	476.8125		76	477.3125
57	476.8375		77	477.3375
58	476.8625		78	477.3625
59	476.8875		79	477.3875
60	476.9125		80	477.4125

Warranty

UHF CB Transceiver UNIDEN XTRAK 80 UNIDEN XTRAK 80 PRO

IMPORTANT: Satisfactory evidence of the original purchase is required for warranty service

Please refer to our Uniden website for any details or warranty durations offered in addition to those contained below.

Warrantor: The warrantor is Uniden Australia Pty Limited ABN 58 001 865 498 (“Uniden”).

Terms of Warranty: Uniden warrants to the original retail purchaser only that the XTRAK 80 / XTRAK 80 PRO UHF CB Transceiver (“the Product”), will be free from defects in materials and craftsmanship for the duration of the warranty period, subject to the limitations and exclusions set out below.

Warranty period: This warranty to the original retail purchaser is only valid in the original country of purchase for a Product first purchased either in Australia or New Zealand.

Product	5 Years
Accessories	1 Year

If a warranty claim is made, this warranty will not apply if the Product is found by Uniden to be:

- (A) Damaged or not maintained in a reasonable manner or as recommended in the relevant Uniden Owner’s Manual;
- (B) Modified, altered or used as part of any conversion kits, subassemblies or any configurations not sold by Uniden;
- (C) Improperly installed contrary to instructions contained in the relevant Owner’s Manual
- (D) Repaired by someone other than an authorized Uniden Repair Agent in relation to a defect or malfunction covered by this warranty; or
- (E) Used in conjunction with any equipment, parts or a system not manufactured by Uniden.

Parts Covered: This warranty covers the Product and included accessories.

User-generated Data: This warranty does not cover any claimed loss of or damage to user-generated data (including but without limitation phone numbers, addresses and images) that may be stored on your Product.

Warranty

Statement of Remedy: If the Product is found not to conform to this warranty as stated above, the Warrantor, at its discretion, will either repair the defect or replace the Product without any charge for parts or service. This warranty does not include any reimbursement or payment of any consequential damages claimed to arise from a Product's failure to comply with the warranty.

Our goods come with guarantees that cannot be excluded under the Australian Consumer Law. You are entitled to a replacement or refund for a major failure and for compensation for any other reasonably foreseeable loss or damage. You are also entitled to have the goods repaired or replaced if the goods fail to be of acceptable quality and the failure does not amount to a major failure.

This warranty is in addition to and sits alongside your rights under either the COMPETITION AND CONSUMER ACT 2010 (Australia) or the CONSUMER GUARANTEES ACT (New Zealand) as the case may be, none of which can be excluded.

Procedure for obtaining warranty service: Depending on the country in which the Product was first purchased, if you believe that your Product does not conform with this warranty, you should deliver the Product, together with satisfactory evidence of your original purchase (such as a legible copy of the sales docket) to Uniden. Please refer to the Uniden website for the address details. You should contact Uniden regarding any compensation that may be payable for your expenses incurred in making a warranty claim. Prior to delivery, we recommend that you make a backup copy of any phone numbers, images or other data stored on your Product, in case it is lost or damaged during warranty service.

UNIDEN AUSTRALIA PTY LTD

Phone: 1300 366 895

Email: custservice@uniden.com.au



THANK YOU FOR BUYING A UNIDEN PRODUCT

Uniden[®]

© 2022 Uniden Australia Pty Limited. Printed in PRC